

Occhio

Sento sospeso

Montageanleitung
Mounting instructions

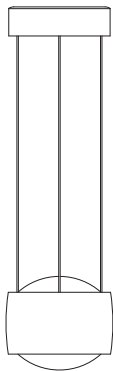

up
flat
trimless



Inhalt / Contents

Sicherheitshinweise	06	Safety precautions	104
Produktbeschreibung	07	Product description	105
Montage head	09	Assembling the head	107
Steuerung mit der Occhio air App (optional)	23	Control using the Occhio air app (optional)	121
Steuerung mit dem Occhio air controller (optional)	31	Control using the Occhio air controller (optional)	129
Montage Leuchte	35	Fitting the luminaire	133
Sento sospeso up mit Höhenverstellung	36	Sento sospeso up with height adjustment	134
Sento sospeso flat mit Höhenverstellung	44	Sento sospeso flat with height adjustment	142
Sento sospeso trimless mit Höhenverstellung	52	Sento sospeso trimless with height adjustment	150
Sento sospeso up fixe Länge	62	Sento sospeso up fixed length	160
Sento sospeso flat fixe Länge	72	Sento sospeso flat fixed length	170
Sento sospeso trimless fixe Länge	82	Sento sospeso trimless fixed length	180
Anhang	97	Appendix	195
Pflegehinweise	98	Care instructions	196
Info & Kontakt	99	Information & contact	197
Technische Daten	100	Technical data	198

Occhio

Sento sospeso

Montageanleitung

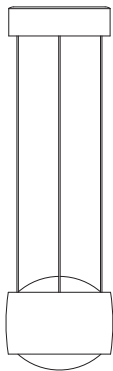

up
flat
trimless

Sicherheitshinweise

Lesen Sie die Montage-/Gebrauchsanweisung sorgfältig durch, bevor Sie die Leuchte installieren. Beachten Sie die Sicherheitshinweise in dieser Anleitung genau und bewahren Sie die Anleitung auf.



Dieses Zeichen macht Sie auf eine gefährliche Situation aufmerksam, die eine schwere Verletzung oder den Tod nach sich ziehen kann, wenn sie nicht beachtet wird. Es macht Sie zudem auf mögliche Sachschäden und andere wichtige Informationen in Verbindung mit diesem Produkt aufmerksam.



Die Montage von Elektrokomponenten darf nur von qualifiziertem Fachpersonal durchgeführt werden. Reparaturarbeiten dürfen nur von autorisiertem Fachpersonal oder dem Hersteller durchgeführt werden. Vor allen Arbeiten am Strahler (Installation, Leuchtmittelwechsel, Reinigung etc.) diesen unbedingt vom Stromnetz trennen.



Dieses Zeichen macht Sie auf Situationen aufmerksam, bei denen Sie direkt in das Licht der LED blicken könnten. Dies kann zu Nachbildern und bei längerer Dauer zu Schädigungen der Augen führen.



Sicherheitsabstand zu brennbaren Objekten einhalten: 20 cm!



Dieses Zeichen macht Sie auf heiße Oberflächen aufmerksam, deren Berührung Verbrennungen zur Folge haben können.

Achtung: Die Oberfläche des Strahlers kann nach längerer Betriebsdauer heiß sein! Vor allen Arbeiten am Strahler (Montage des Strahlers, Wechsel des Leuchtmittels, Wechsel der Inserts, usw.), Strahler immer ausschalten und mindestens 30 Minuten abkühlen lassen.

Produktbeschreibung

LED Pendelleuchte mit beidseitigem Lichtaustritt, Lichtleistung 32 W (26 W bei Version chrom glanz). Verhältnis von up- und downlight frei einstellbar. Lichtwirkung über optionale inserts veränderbar.

up-Version mit Höhenverstellung

Stufenlose Höhenverstellung und hohe base inkl. Vorschaltgerät (Konverter) für Montage auf fester Decke, Anschluß an 230V. Extern dimmbar per Phasenabschnittdimmer oder über Gestensteuerung »touchless control« am head.

flat-Version mit Höhenverstellung

Stufenlose Höhenverstellung und flache base für Montage auf Hohlraumdose, Anschluß an externe Konstantspannungsquelle (Konverter). Extern dimmbar (abhängig vom Vorschaltgerät) oder über Gestensteuerung »touchless control« am head.

trimless-Version mit Höhenverstellung

Stufenloser Höhenverstellung inkl. Deckenelement zum bündigen Einbau in Hohlraumdecke. Anschluß an externe Konstantspannungsquelle (Konverter). Extern dimmbar (abhängig vom Vorschaltgerät) oder über Gestensteuerung »touchless control« am head.

up-Version fixe Länge

Fest einstellbare Höhe bei Montage und hoher base inkl. Vorschaltgerät (Konverter) für Montage auf fester Decke, Anschluß an 230V. Extern dimmbar per Phasenabschnittdimmer oder über Gestensteuerung »touchless control« am head.

flat-Version fixe Länge

Fest einstellbarer Höhe bei Montage und flacher base für Montage auf Hohlraumdose, Anschluß an externe Konstantspannungsquelle (Konverter). Extern dimmbar (abhängig vom Vorschaltgerät) oder über Gestensteuerung »touchless control« am head.

trimless-Version fixe Länge

Fest einstellbarer Höhe bei Montage inkl. Deckenelement zum bündigen Einbau in Hohlraumdecke. Anschluß an externe Konstantspannungsquelle (Konverter). Extern dimmbar (abhängig vom Vorschaltgerät) oder über Gestensteuerung »touchless control« am head.

Montage head

Montage head (inserts)



Linse



Diffusorglas

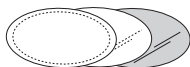

soft edge Glas,
satiniertes Glas oder
Farbfilter (optional)



Farbfilter (optional)

head

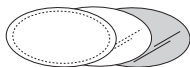
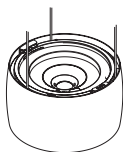

soft edge Glas,
satiniertes Glas oder
Farbfilter (optional)

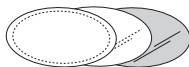

soft edge Glas,
satiniertes Glas oder
Farbfilter (optional)



Linse

Version D



Linse

Version E



Montage head (inserts)

Farbfilter / Diffusorglas

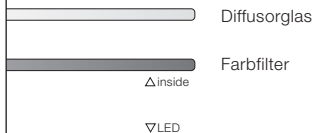

Farbfilter / Linse

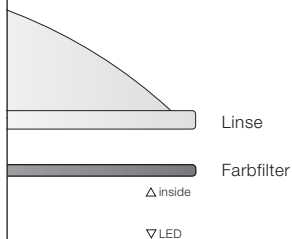

soft edge Glas / Linse

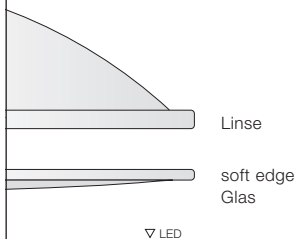

Achtung: Die Oberfläche des Strahlers kann nach längerer Betriebsdauer heiß sein! Vor allen Arbeiten am Strahler diesen immer ausschalten und mindestens 30 Minuten abkühlen lassen.



Achtung: Nicht direkt in die brennende LED blicken! Dies kann zu Nachbildern und bei längerer Dauer zu Schädigungen der Augen führen! LED nicht berühren. Sie kann dadurch beschädigt werden!

Montage head (inserts)

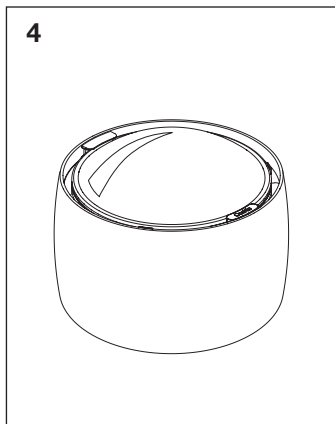
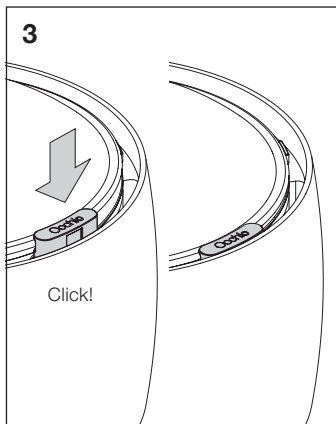
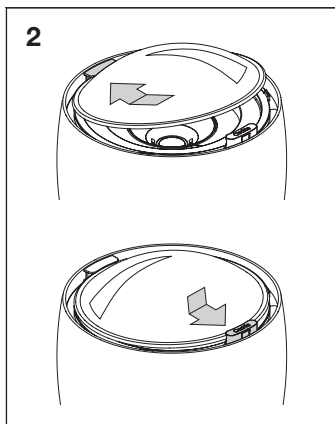
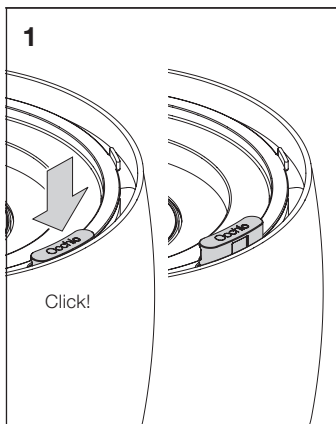

Montage spot Linse (optional)

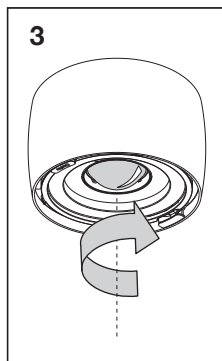
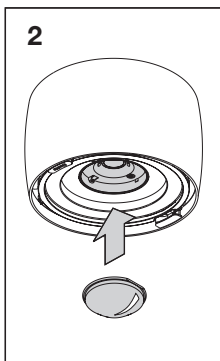
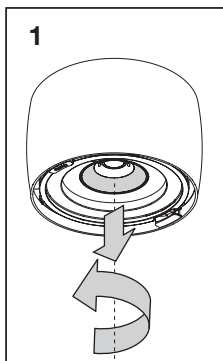

spot Linse entnehmen

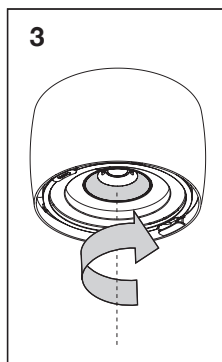
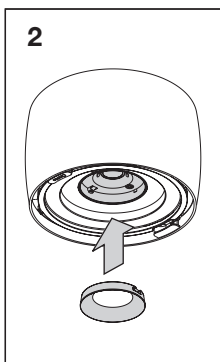
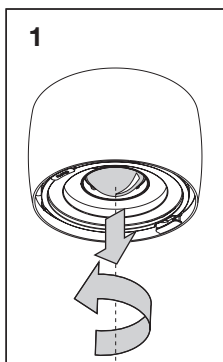



touchless control
up/down fading

head auf DIM einstellen

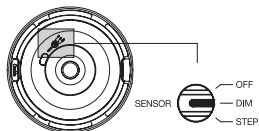

OFF Extern schalten und dimmen

DIM »touchless control«
»touchless fading«
Berührungslose Steuerung

STEP »up / down preset«
Voreinstellung Lichtverhältnis
von up- und downlight
Extern schalten und dimmen

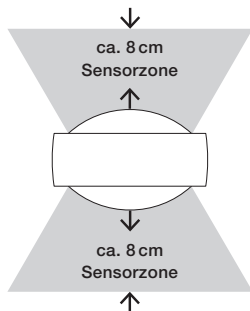

ca. 8 cm
Sensorzone

ca. 8 cm
Sensorzone

Bedienung »touchless control«

ON/OFF

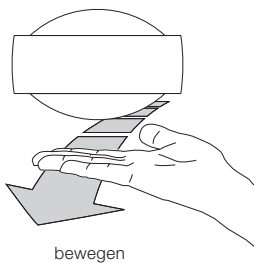

bewegen

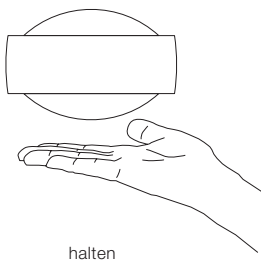
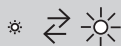

halten

Bedienung »touchless fading«

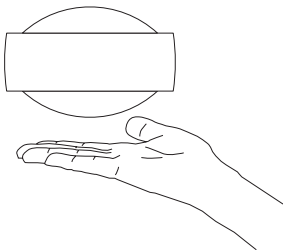

lange halten

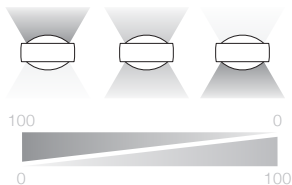

Maximale Helligkeit auf eine Seite des Lichtaustritts ziehen

up- und downlight koppeln / entkoppeln

(ent)koppeln

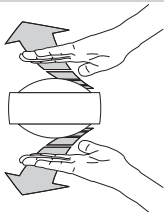

gleichzeitig bewegen
Die Leuchte blinkt
zur Bestätigung

ON/OFF

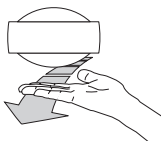

bewegen
Beide Seiten
zusammen schalten

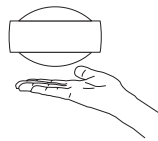
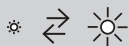

halten
Beide Seiten
zusammen dimmen

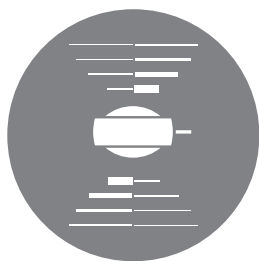

up/down
preset

head auf STEP einstellen

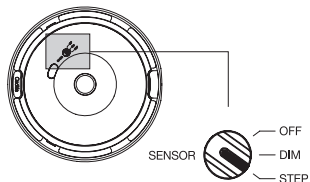

- OFF** Extern schalten und dimmen
DIM »touchless control«
»touchless fading«
Berührungslose Steuerung
STEP »up / down preset«
Voreinstellung Lichtverhältnis
von up- und downlight
Extern schalten und dimmen

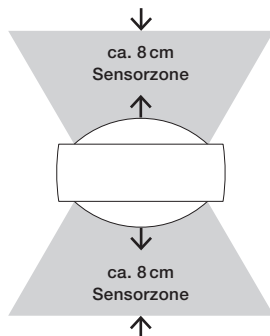

up / down-Verhältnis einstellen und speichern

1

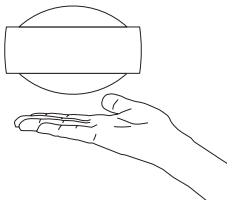

10 sek. halten

Leuchte wird entsperrt und
blinkt zur Bestätigung

2

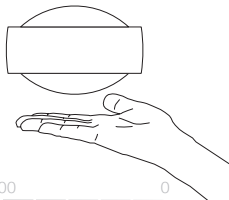

lange halten

Lichtverhältnis in 5 Stufen einstellen

3

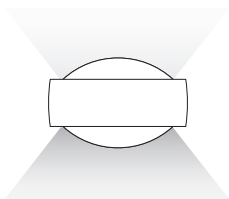

5 min. warten oder
netzseitig aus-/einschalten

Einstellung ist nun gespeichert

4

ON/OFF – DIM

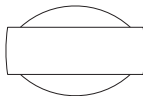

Schalter /
Dimmer*

Schalten und Dimmen

Leuchte bleibt in der
gespeicherten Einstellung

Steuerung mit
der Occhio air
App (optional)

Control using
the Occhio air
app (optional)

Steuerung mit der Occhio air App (optional) Control using the Occhio air app (optional)

Quick guide

Die Occhio air Produkte lassen sich mit der Occhio air App einrichten und steuern.

App installieren, App öffnen und angeschlossene Leuchten einrichten.

Occhio air products can be set up and controlled using the Occhio air app.

Install App, open App and set up connected luminaires.



Occhio air tutorials

www.occhio.de/air-tutorials

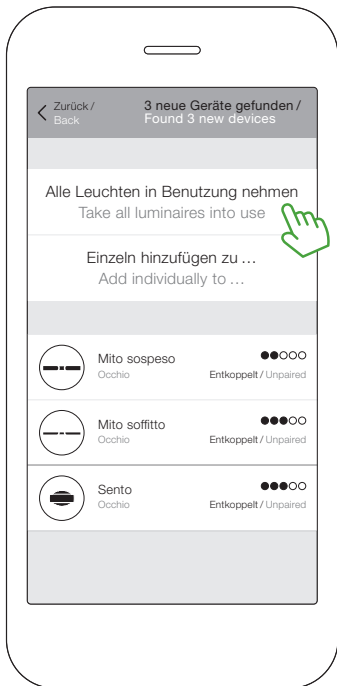

Ein Netzwerk (mein Netzwerk) wird autom. erstellt.

A network (my network) is autom. created.

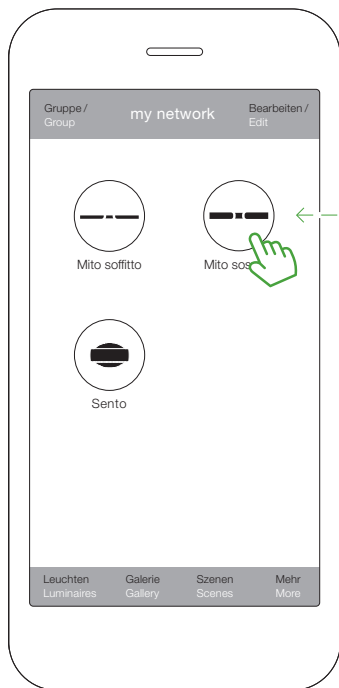

Steuerungsgesten Control gestures

on / off
on / off



antippen
tap

dimmen
dim



wischen
swipe

up / down
faden *



wischen
swipe

color tune **



halten
hold



wischen
swipe

* Leuchten mit beidseitigem Lichtaustritt /
luminaires with light emission on both sides

** Mito

Und so werden die Leuchten gesteuert.
And so the luminaires are controlled.

Steuerung mit der Occhio air App (optional) Control using the Occhio air app (optional)

Nutzung auf mehreren Geräten

Use on several devices

Optional können Sie nun ihr
erstelltes Netzwerk (mein
Netzwerk) mit Anderen teilen.

Optionally, you can now share
your created network (my
network) with others.

1. Netzwerknamen
vergeben

1. Assign name

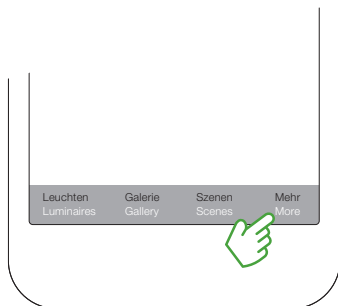

Occhio air tutorials

www.occhio.de/air-tutorials

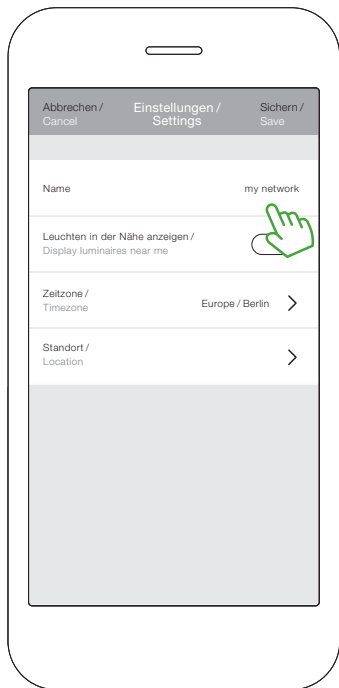

Netzwerkconfiguration → Netzwerkeinstellungen → Namen eingeben → Sichern
Network setup → Network settings → enter name → save

Steuerung mit der Occhio air App (optional) Control using the Occhio air app (optional)

Netzwerk freigeben
und schützen

Share and protect the
network

Occhio air tutorials
www.occhio.de/air-tutorials

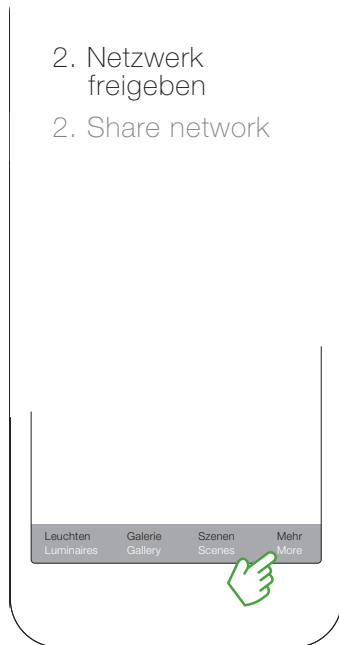

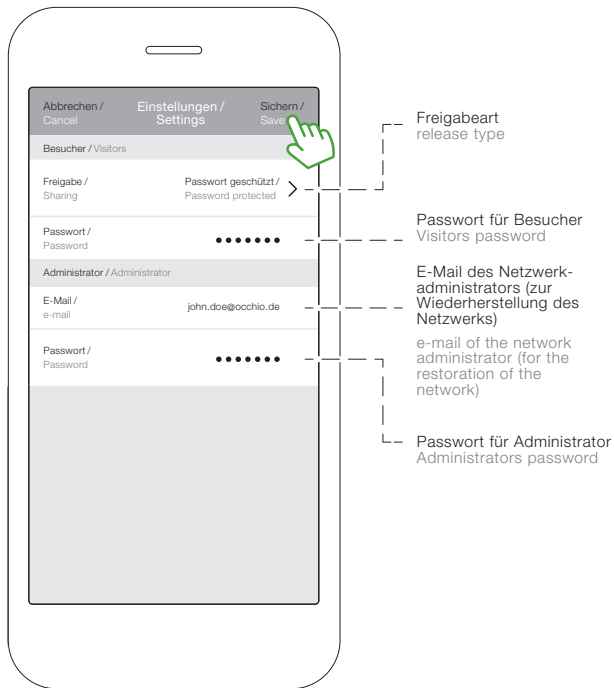

Netzwerkconfiguration → Freigabeoptionen → Passwort geschützt → Sichern
 Network setup → Sharing settings → Password protected → save

Steuerung mit
dem Occhio air
controller
(optional)

Control using
the Occhio air
controller
(optional)

Steuerung mit dem Occhio air controller (optional) Control using the Occhio air controller (optional)

Occhio air controller

Intuitiv bedienbare Fernbedienung mit vier programmierbaren Tasten (Einrichtung via Occhio air App). Unabhängig von der App können einzelne Leuchten, Gruppen und Szenen gesteuert werden. Optional mit Wandhalterung erhältlich.

Maximaler Bedienkomfort und umfassende Steuerung via Bluetooth 4.0 (Bluetooth Low Energy). Schalten, dimmen, faden, color tune von einzelnen Leuchten, Gruppen und Szenen.

Occhio air controller

Intuitive remote control with four programmable buttons (setup via Occhio air app). Individual luminaires, groups and scenes can be controlled regardless of the app. Available with optional wall mount.

Maximum ease of use and total control via Bluetooth 4.0 (Bluetooth low energy). Switching, dimming, fading, color tune of individual luminaires, groups and scenes.



Zum Einrichten des Occhio air controllers wird die Occhio air App benötigt. Eine Video-Kurzanleitung kann unter: www.occhio.de/air-tutorials aufgerufen werden.

To set up the Occhio air controller, the Occhio air app is required. A video quick start guide can be called up at www.occhio.de/air-tutorials.

schalten/switch



⏏ - ☰ einzelne Leuchten, Gruppen, oder Szenen schalten

⏏ - ☰ switch individual luminaires, groups or scenes

dimmen/dim



⊕ - ☰ einzelne Leuchten, Gruppen, oder Szenen dimmen

⊕ - ☰ dims individual luminaires, groups or scenes

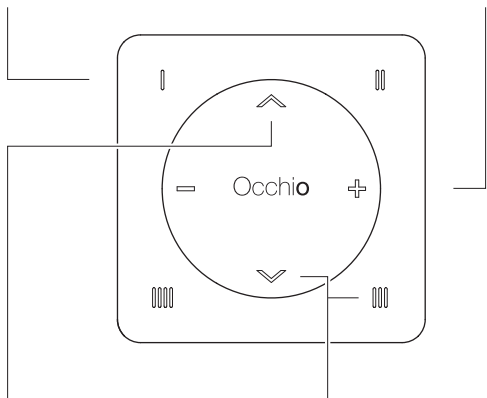

faden*



⤴ ⤵ einzelne Leuchten, Gruppen oder Szenen faden (up/down Verhältnis ändern)

⤴ ⤵ fades individual luminaires, groups or scenes (change up/down relation)

color tune**

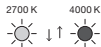





⏏ - ☰ and ⤴ ⤵ Farbtemperatur einzelner Leuchten, Gruppen oder Szenen einstellen

⏏ - ☰ and ⤴ ⤵ adjust color temperature of individual luminaires, groups or scenes

* Leuchten mit beidseitigem Lichtaustritt / luminaires with light emission on both sides ** Mito

Montage Leuchte

	Sento sospeso up mit Höhenverstellung für feste Decke, Vorschaltgerät integriert	36
	Sento sospeso flat mit Höhenverstellung für Hohlraum-/Einputzdose, Vorschaltgerät extern	44
	Sento sospeso trimless mit Höhenverstellung mit Einbauplatte, Vorschaltgerät extern	52
	Sento sospeso up fixe Länge für feste Decke, Vorschaltgerät integriert	62
	Sento sospeso flat fixe Länge für Hohlraum-/Einputzdose, Vorschaltgerät extern	72
	Sento sospeso trimless fixe Länge mit Einbauplatte, Vorschaltgerät extern	82

Sento sospeso up mit Höhenverstellung

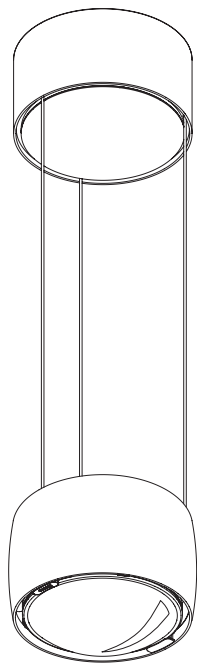



230 V AC
Netzanschlussleitung



Baldachin

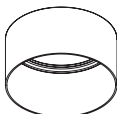

Montageplatte

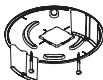

Occhio Konverter

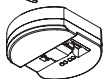

Montagering

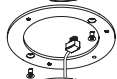

Kabelaufwicklung
mit Stecker



Cover



head

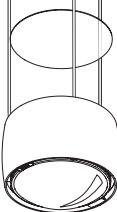

Sento sospeso up mit Höhenverstellung

230 V AC
Netzanschlussleitung

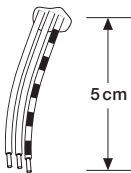

Netzkabel auf 5 cm ablängen und
Enden abisolieren.

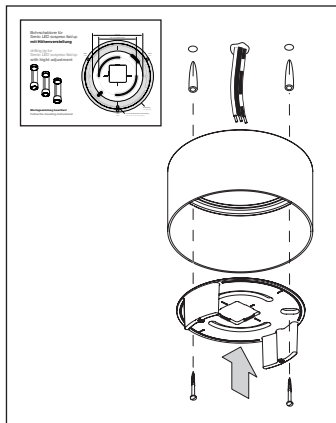

Positionen der Bohrlöcher mit bei-
liegender Bohrschablone ermitteln.
Die Ausrichtung der Montageplatte
bestimmt die späteren Positionen
der Abhängekabel! Bei mehreren
Leuchten auf gleiche Ausrichtung
achten! **Auf den Verlauf von
Stromleitungen achten!**

Zwei Löcher \varnothing 6 mm bohren, Dübel
bündig einsetzen und Baldachin
mit Montageplatte anschrauben
(Schrauben und Dübel sind im
Lieferumfang enthalten). Darauf
achten, dass die Schrauben bündig
mit der Montageplatte abschließen.

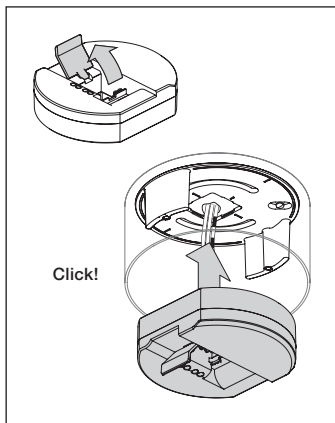

Klappe in der Mitte des Konverters mit Hilfe eines Schraubendrehers öffnen.

Konverter bündig in die Montageplatte einrasten.

Dabei die Enden der Netzleitung durch die Öffnung des Konverters führen.

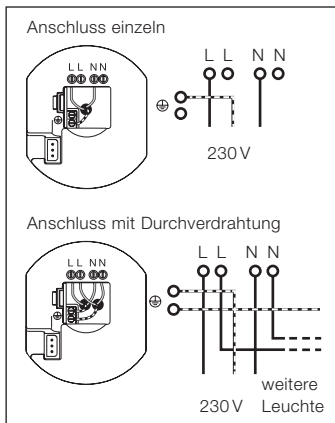

Kabelenden der Netzleitung nach Schema an die Klemmen des Konverters anschließen.



Achtung!
Vor der Montage alle stromführenden Leitungen vom Stromnetz trennen!

Sento sospeso up mit Höhenverstellung

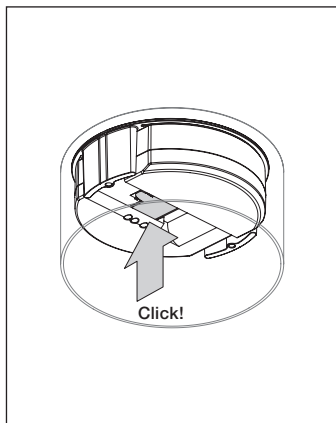

Klappe des Konverters schließen.

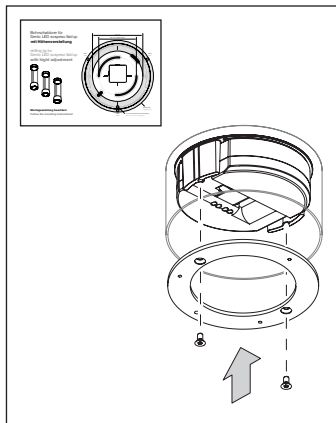

Montagering mit mitgelieferten Schrauben (Inbus) an beide Abstandshalter der Montageplatte schrauben.

Auf die richtige Ausrichtung des Montagerings achten (siehe Bohrschablone)!

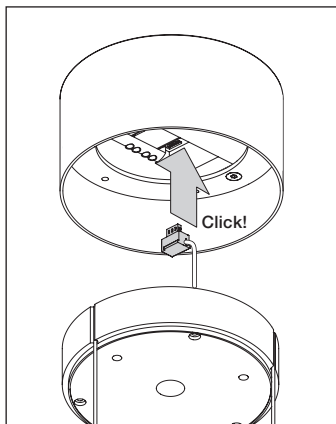

Stecker der Leuchte in eine der beiden Buchsen des Konverters stecken (LED 1 oder LED 2).

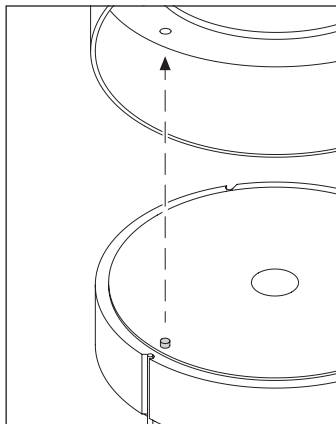

Kabelaufwicklung in den Baldachin schieben und so drehen, dass der Positionierstift in den Montagering einrastet.

Darauf achten, dass die Kabel bündig in den seitlichen Nuten liegen.

Sento sospeso up mit Höhenverstellung

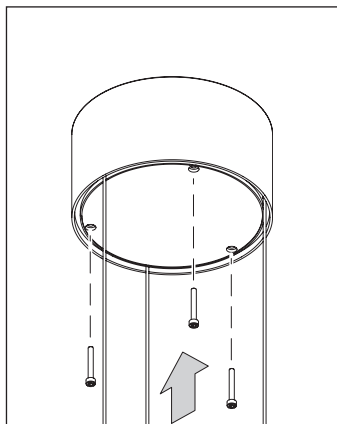

Kabelaufwicklung mit mitgelieferten Schrauben (Inbus) an den Montagering schrauben.

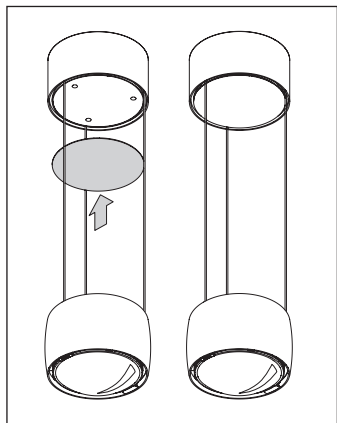

Cover aufsetzen. Es wird magnetisch gehalten.

Die Leuchte ist nun fertig montiert.

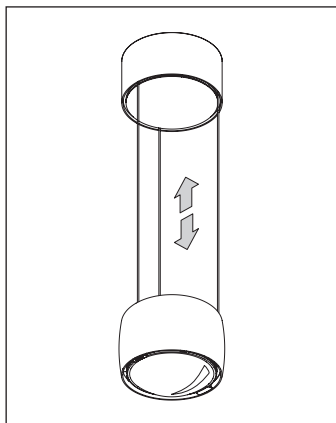

Bedienung Höhenverstellung

head mit beiden Händen senkrecht nach unten ziehen oder nach oben bewegen. Die Kabel wickeln sich automatisch in der Kabelaufwicklung auf.

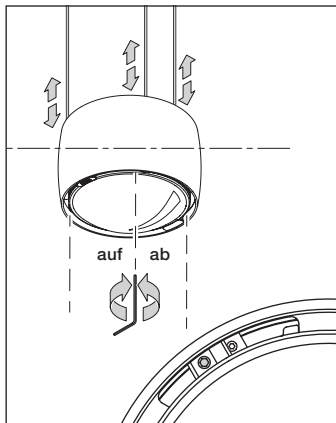

Head waagrecht einstellen

Zuerst head mit beiden Händen senkrecht möglichst weit herausziehen und wieder nach oben bewegen. Die Kabel wickeln sich gleichmäßig auf.

Hängt der head danach immer noch nicht waagrecht, kann er mit beiliegendem Inbusschlüssel ± 5 mm an allen drei Abhängungen nachjustiert werden.

Sento sospeso flat mit Höhenverstellung

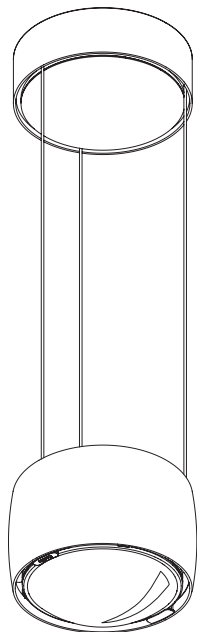



Hohlraumdose
(bauseitig)

Baldachin

Montageplatte

Montagering

Kabelaufwicklung
mit Stecker

Cover

head

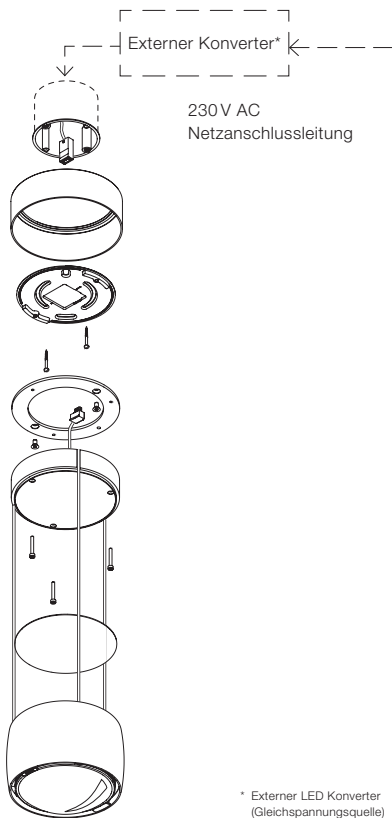

Externer Konverter*

230 V AC
Netzanschlussleitung

* Externer LED Konverter
(Gleichspannungsquelle)
48V DC, min. 40W

Sento sospeso flat mit Höhenverstellung

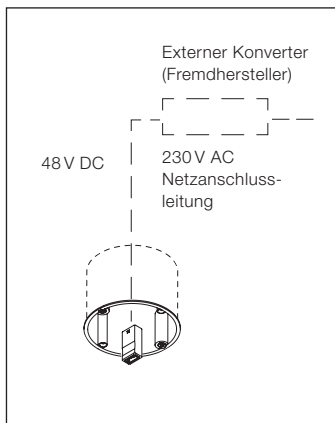

Konverter eines Fremdherstellers anschließen (siehe Beiblatt zum Konverter):

Konverter nach Schema an die Netzleitung anschließen. Kabel mit LED-Buchse an den Konverter anschließen. Technische Hinweise des jeweiligen Herstellers beachten! **Schwarz = Pluspol, Weiß = Minuspol** Buchse des LED Verlängerungskabels durch die Hohlraum- / Einputzdose nach außen führen.

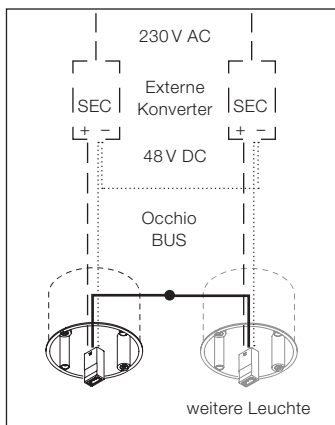

Occhio BUS (optional)

Durch Verbinden der Occhio BUS Kabel ist es möglich, mehrere Leuchten synchron mit »touchless control« zu steuern. Dazu die Einstellung am head auf „DIM“ einstellen.

Die mit BUS gekennzeichneten Kabel mit einer geeigneten Klemme miteinander verbinden. Bei mehreren Convertern müssen die Minuspole (SEC) miteinander verbunden werden. Andere Kabel wie oben angegeben anschließen.

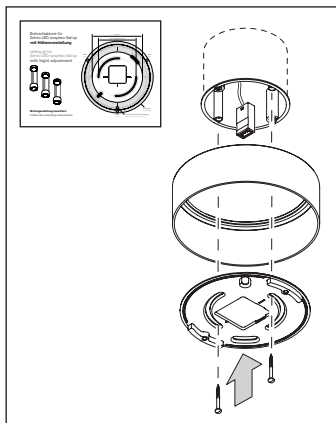

Richtige Ausrichtung der Montageplatte mit beiliegender Schablone ermitteln. Die Ausrichtung der Montageplatte bestimmt die späteren Positionen der Abhängenkabel! Bei mehreren Leuchten auf gleiche Ausrichtung achten!

Baldachin mit Montageplatte an die Hohlraumdose schrauben. Dabei die Buchse des LED-Anschlusskabels durch die Öffnung führen. Darauf achten, dass die Schrauben bündig mit der Montageplatte abschließen.

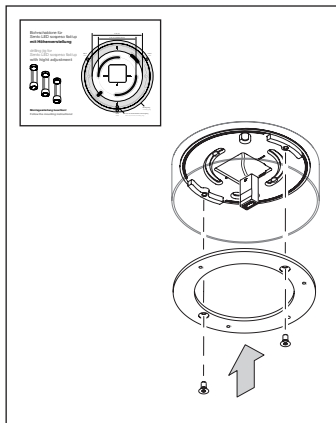

Montagering mit mitgelieferten Schrauben (Inbus) an beide Abstandshalter der Montageplatte schrauben.

Auf die richtige Ausrichtung des Montagerings achten (siehe Bohrschablone)!



Achtung!
Vor der Montage alle stromführenden Leitungen vom Stromnetz trennen!

Sento sospeso flat mit Höhenverstellung

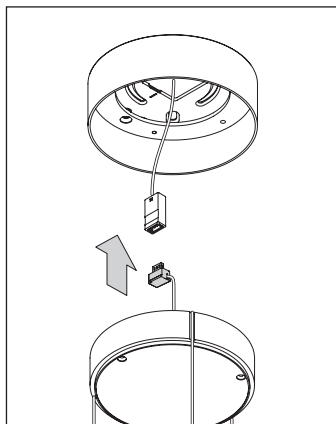

Stecker der Leuchte mit der Buchse des LED-Anschlusskabels verbinden.

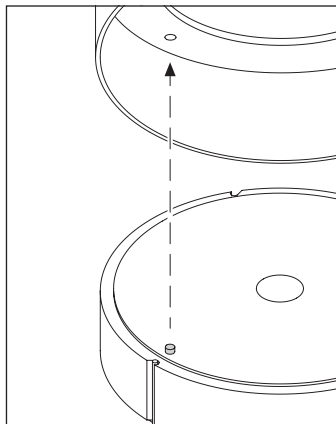

Kabelaufwicklung in den Baldachin schieben und so drehen, dass der Positionierstift in den Montagering einrastet.

Darauf achten, dass die Kabel bündig in den seitlichen Nuten liegen.

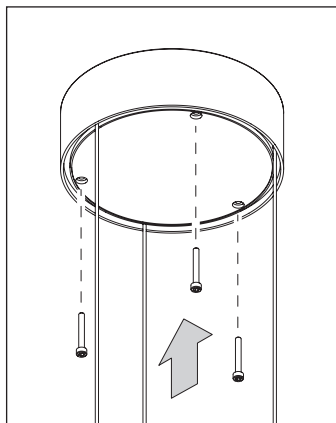

Kabelaufwicklung mit mitgelieferten Schrauben (Inbus) an den Montagering schrauben.

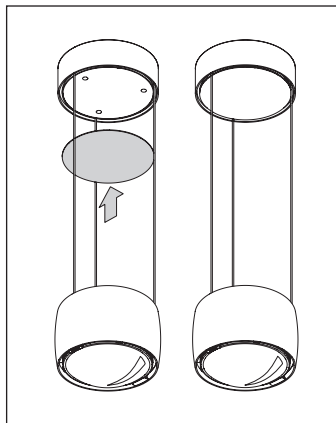

Cover aufsetzen. Es wird magnetisch gehalten.

Die Leuchte ist nun fertig montiert.

Sento sospeso flat mit Höhenverstellung

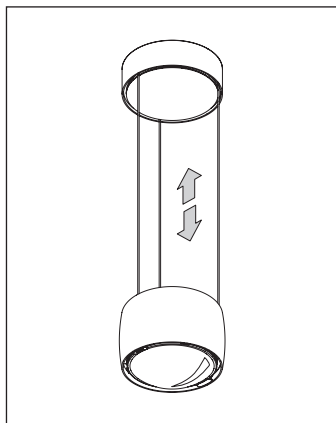

Bedienung Höhenverstellung

head mit beiden Händen senkrecht nach unten ziehen oder nach oben bewegen. Die Kabel wickeln sich automatisch in der Kabelaufwicklung auf.

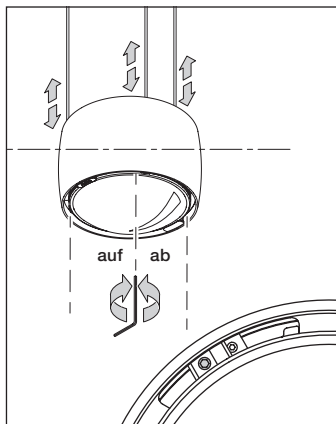

Head waagrecht einstellen

Zuerst head mit beiden Händen senkrecht möglichst weit herausziehen und wieder nach oben bewegen. Die Kabel wickeln sich gleichmäßig auf.

Hängt der head danach immer noch nicht waagrecht, kann er mit beiliegendem Inbusschlüssel ± 5 mm an allen drei Abhängungen nachjustiert werden.



Sento sospeso trimless
mit Höhenverstellung

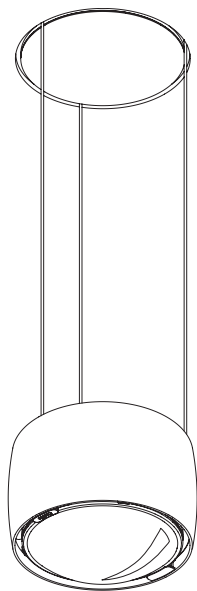



Ausschnitt:
> 250 x 250 mm

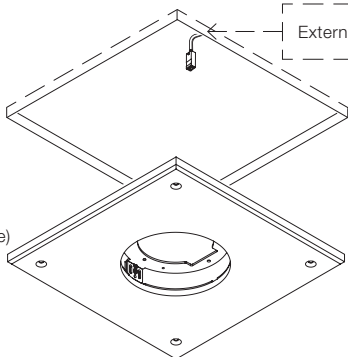

Externer Konverter*

230 V AC
Netzanschluss-
leitung

Einbauplatte
(Faserzementplatte)
250 x 250 mm
Dicke: 12,5 mm

Kabelaufwicklung
mit Stecker

Cover

head

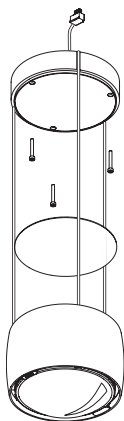

* Externer LED Konverter (Gleichspannungsquelle) 48 V DC, min. 40 W

Sento sospeso trimless mit Höhenverstellung

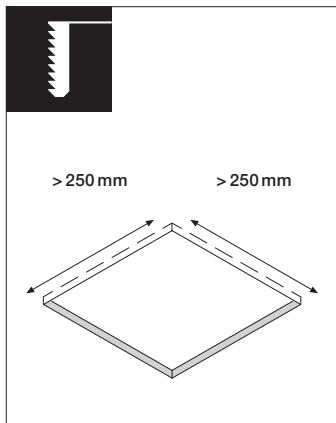

Deckenausschnitt im Format
> 250 x 250 mm herstellen.

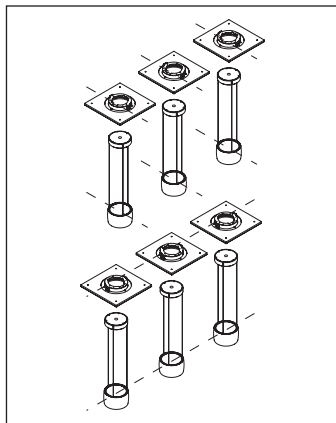

**Richtige Ausrichtung der
Einputzplatte beachten! Die
Ausrichtung der Einputzplatte
bestimmt die späteren Positio-
nen der Abhängekabel!**

**Bei mehreren Leuchten auf
gleiche Ausrichtung achten!**

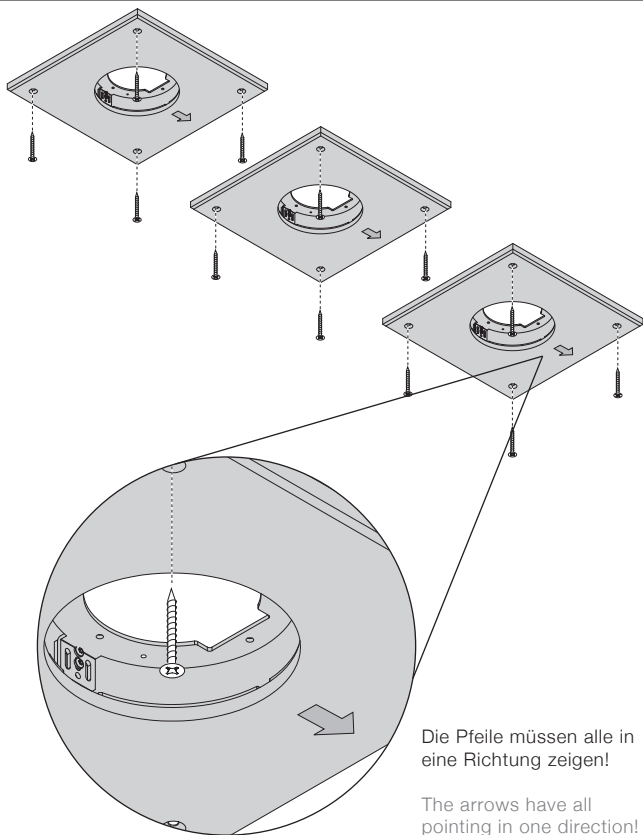

Die Pfeile müssen alle in eine Richtung zeigen!

The arrows have all pointing in one direction!

Sento sospeso trimless mit Höhenverstellung

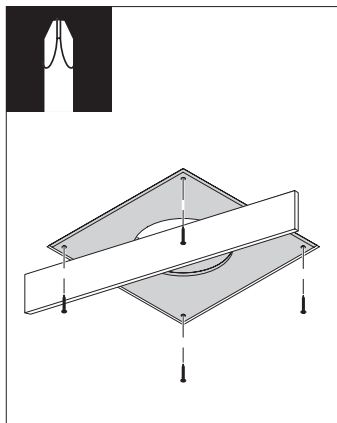

Einputzplatte fachgerecht bündig in der Öffnung montieren. Dazu vorgesehene Bohrlöcher verwenden. Wird die Platte an anderen Stellen fixiert, vor dem Anschrauben vorbohren, um die Einputzplatte nicht zu beschädigen.



Achtung!

Der Hersteller weist ausdrücklich darauf hin, dass eine nicht fachgerecht installierte Einputzplatte herabfallen kann und eine erhebliche Gefahr darstellt!

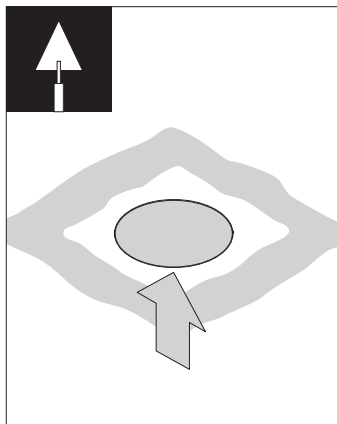

Schutzhaube in die Öffnung einsetzen.

Fugen verputzen.

Darauf achten, dass die Innenseite des Montagerings nicht verschmutzt wird.

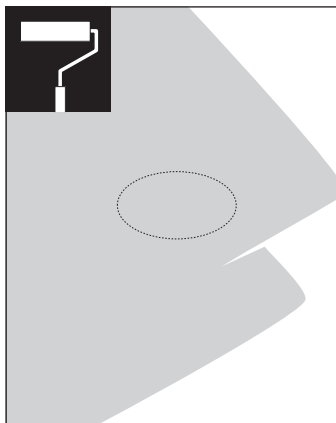

Malerarbeiten ausführen.

Darauf achten, dass die Innenseite des Montagerings nicht verschmutzt wird.

Schutzhaube entfernen.

Putz- / Farbreste auf der Innenfläche des Einbaurings ggf. mit feinem Schleifpapier entfernen.



Achtung!
Vor der Montage alle stromführenden Leitungen vom Stromnetz trennen!

Sento sospeso trimless mit Höhenverstellung

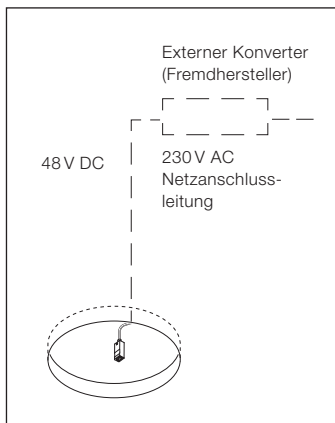

Konverter eines Fremdherstellers anschließen (siehe Beiblatt zum Konverter):

Konverter nach Schema an die Netzleitung anschließen. Kabel mit LED-Buchse an den Konverter anschließen. Technische Hinweise des jeweiligen Herstellers beachten! **Schwarz = Pluspol, Weiß = Minuspol** Buchse des LED Verlängerungskabels durch die Hohlraum- / Einputzdose nach außen führen.

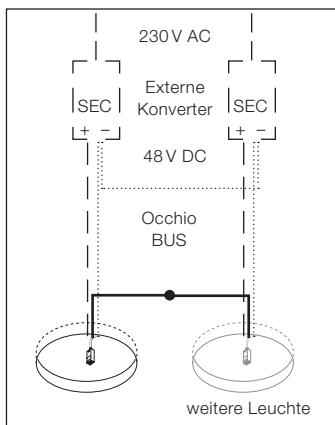

Occhio BUS (optional)

Durch Verbinden der Occhio BUS Kabel ist es möglich, mehrere Leuchten synchron mit »touchless control« zu steuern. Dazu die Einstellung am head auf „DIM“ einstellen.

Die mit BUS gekennzeichneten Kabel mit einer geeigneten Klemme miteinander verbinden. Bei mehreren Convertern müssen die Minuspole (SEC) miteinander verbunden werden. Andere Kabel wie oben angegeben anschließen.

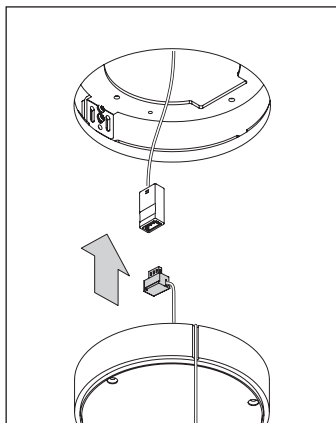

Stecker der Leuchte mit der Buchse des LED-Anschlusskabels verbinden.

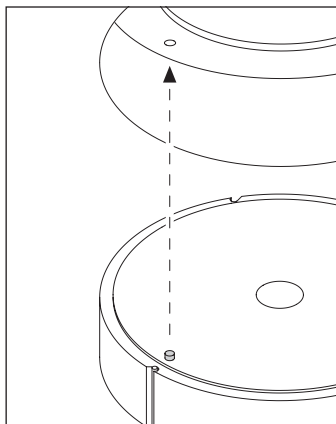

Kabelaufwicklung in den Baldachin schieben und so drehen, dass der Positionierstift in den Montagering einrastet.

Darauf achten, dass die Kabel bündig in den seitlichen Nuten liegen.

Sento sospeso trimless mit Höhenverstellung

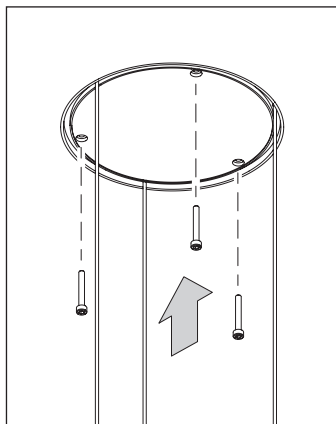

Kabelaufwicklung mit mitgelieferten Schrauben (Inbus) an die Halterung schrauben.

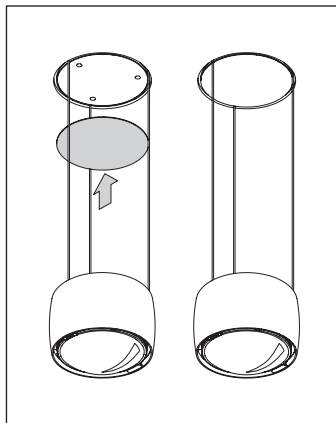

Cover aufsetzen. Es wird magnetisch gehalten.

Die Leuchte ist nun fertig montiert.

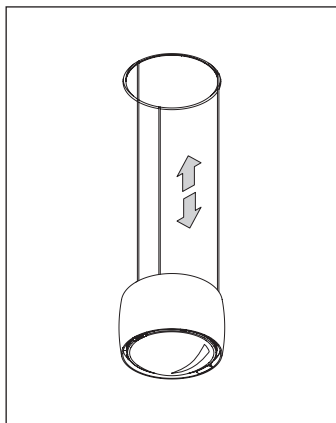

Bedienung Höhenverstellung

head mit beiden Händen senkrecht nach unten ziehen oder nach oben bewegen. Die Kabel wickeln sich automatisch in der Kabelaufwicklung auf.

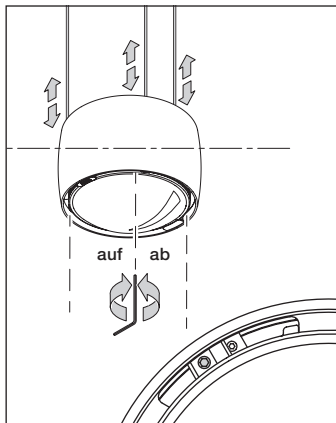

Head waagrecht einstellen

Zuerst head mit beiden Händen senkrecht möglichst weit herausziehen und wieder nach oben bewegen. Die Kabel wickeln sich gleichmäßig auf.

Hängt der head danach immer noch nicht waagrecht, kann er mit beiliegendem Inbusschlüssel ± 5 mm an allen drei Abhängungen nachjustiert werden.

Sento sospeso up
fixe Länge

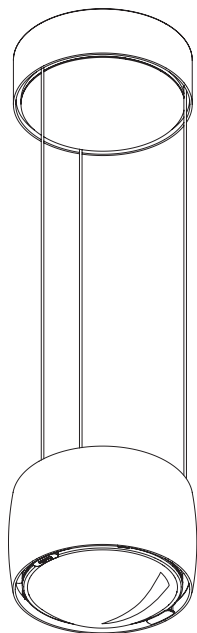



↓
230 V AC
Netzanschlussleitung



Baldachin



Montageplatte



Occhio Konverter



Kabelhalterung



Kabelabdeckung



Cover

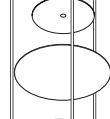

head



Sento sospeso up fixe Länge

230 V AC
Netzanschlussleitung

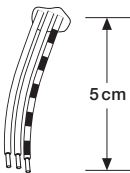

Netzkabel auf 5 cm ablängen und
Enden abisolieren.

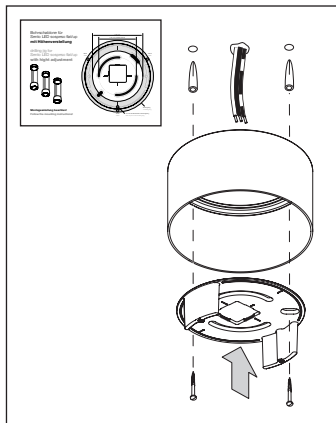

Positionen der Bohrlöcher mit bei-
liegender Bohrschablone ermitteln.
Die Ausrichtung der Montageplatte
bestimmt die späteren Positionen
der Abhängekabel! Bei mehreren
Leuchten auf gleiche Ausrichtung
achten! **Auf den Verlauf von
Stromleitungen achten!**

Zwei Löcher \varnothing 6 mm bohren, Dübel
bündig einsetzen und Baldachin
mit Montageplatte anschrauben
(Schrauben und Dübel sind im
Lieferumfang enthalten). Darauf
achten, dass die Schrauben bündig
mit der Montageplatte abschließen.

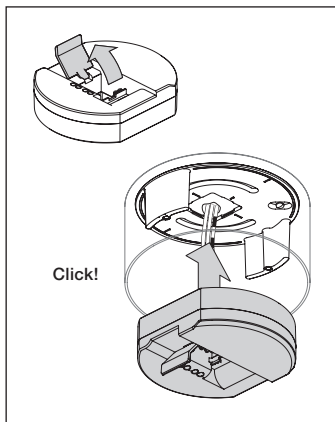

Klappe in der Mitte des Konverters mit Hilfe eines Schraubendrehers öffnen.

Konverter bündig in die Montageplatte einrasten.

Dabei die Enden der Netzleitung durch die Öffnung des Konverters führen.

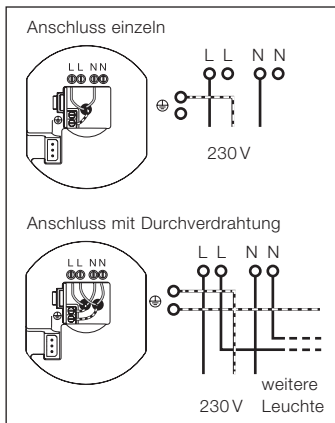

Kabelenden der Netzleitung nach Schema an die Klemmen des Konverters anschließen.



Achtung!
Vor der Montage alle
stromführenden Leitungen
vom Stromnetz trennen!

Sento sospeso up fixe Länge

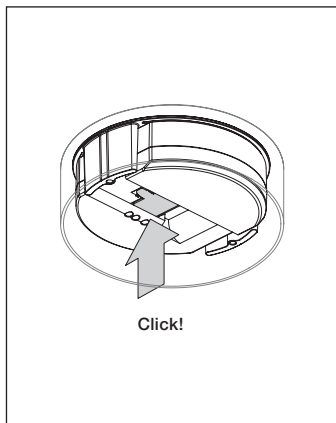

Klappe des Konverters schließen.

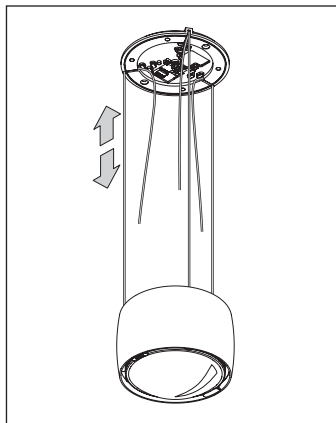

Länge der Abhängung durch
Ziehen grob einstellen.

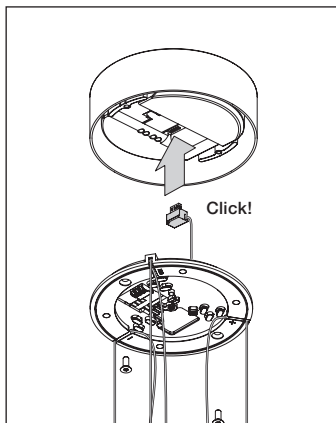

Stecker der Leuchte in eine der beiden Buchsen des Konverters stecken (LED 1 oder LED 2).

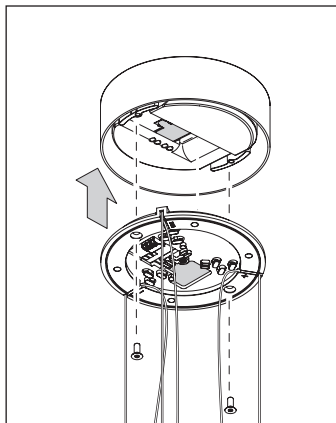

Kabelhalter wie in der Abbildung ausrichten!

Kabelhalter mit mitgelieferten Schrauben (Inbus) an beide Abstandshalter der Montageplatte schrauben.

Sento sospeso up fixe Länge

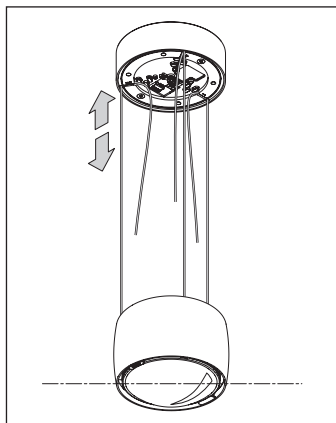

Endgültige Länge der Kabel durch Ziehen einstellen. Dabei darauf achten, dass alle drei Kabel genau gleich lang sind und der head waagrecht hängt.

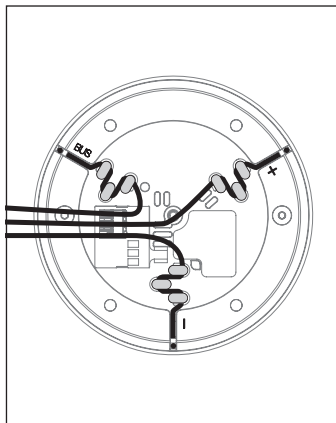

Alle drei losen Kabel nach Schema in die jeweilige Zugentlastung einfädeln.

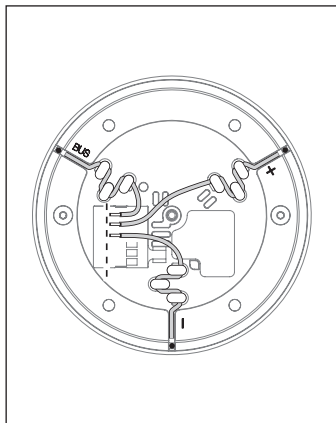

Kabel passend kürzen und an den Enden 6–7 mm abisolieren.

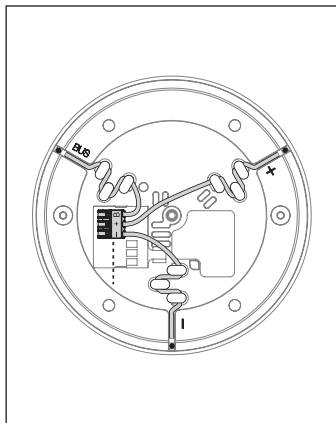

Alle Kabel an die Klemmen anschließen.

Polung beachten!

Sento sospeso up fixe Länge

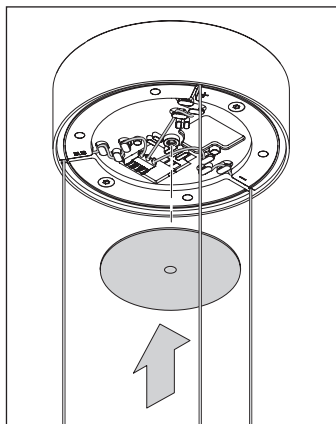

Kabelabdeckung an die Kabelhalterung schrauben.

Darauf achten, dass die Kabel alle flach anliegen.

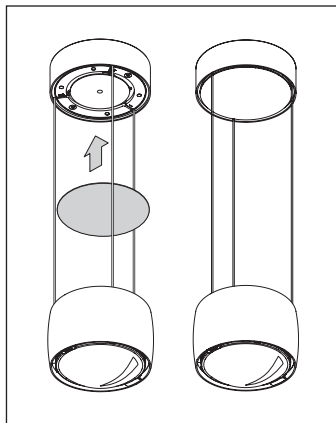

Cover aufsetzen. Es wird magnetisch gehalten.

Die Leuchte ist nun fertig montiert.

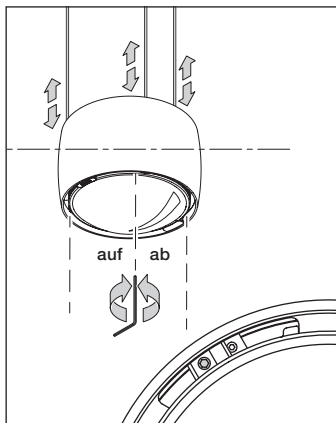

Head waagrecht einstellen

Hängt der head nicht ganz waagrecht, kann er mit beiliegendem Inbusschlüssel ± 5 mm an allen drei Abhängungen nachjustiert werden.

Sento sospeso flat
fixe Länge

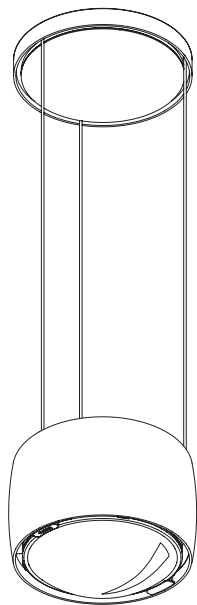



Hohlraumdose
(bauseitig)

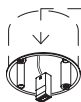

Externer Konverter*

230 V AC
Netzanschluss-
leitung

Baldachin



Montageplatte



Kabelhalterung



Kabelabdeckung



Cover

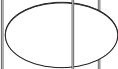

head



* Externer LED Konverter
(Gleichspannungsquelle)
48V DC, min. 40 W

Sento sospeso flat fixe Länge

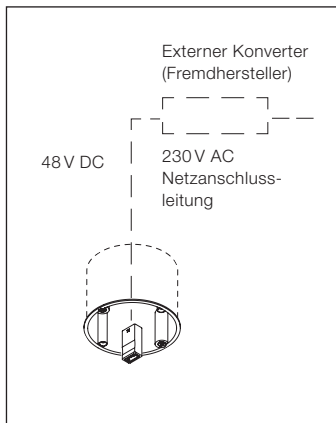

Konverter eines Fremdherstellers anschließen (siehe Beiblatt zum Konverter):

Konverter nach Schema an die Netzleitung anschließen. Kabel mit LED-Buchse an den Konverter anschließen. Technische Hinweise des jeweiligen Herstellers beachten! **Schwarz = Pluspol, Weiß = Minuspol** Buchse des LED Verlängerungskabels durch die Hohlraum- / Einputzdose nach außen führen.

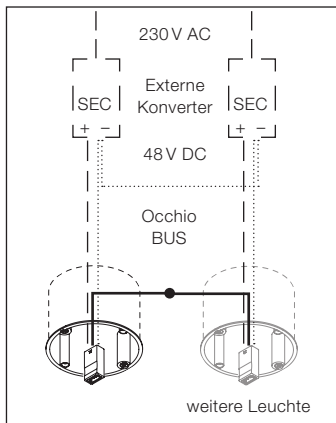

Occhio BUS (optional)

Durch Verbinden der Occhio BUS Kabel ist es möglich, mehrere Leuchten synchron mit »touchless control« zu steuern. Dazu die Einstellung am head auf „DIM“ einstellen.

Die mit BUS gekennzeichneten Kabel mit einer geeigneten Klemme miteinander verbinden. Bei mehreren Convertern müssen die Minuspole (SEC) miteinander verbunden werden. Andere Kabel wie oben angegeben anschließen.

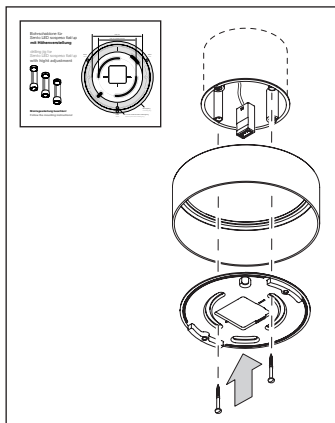

Richtige Ausrichtung der Montageplatte mit beiliegender Schablone ermitteln. Die Ausrichtung der Montageplatte bestimmt die späteren Positionen der Abhängkabel! Bei mehreren Leuchten auf gleiche Ausrichtung achten!

Baldachin mit Montageplatte an die Hohlraumdose schrauben. Dabei die Buchse des LED-Anschlusskabels durch die Öffnung führen. Darauf achten, dass die Schrauben bündig mit der Montageplatte abschließen.

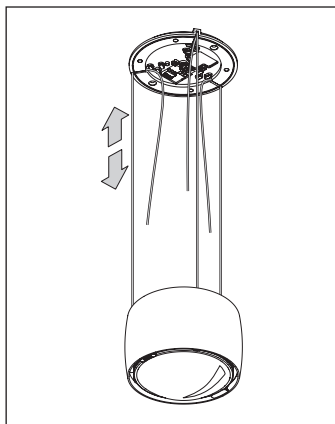

Länge der Abhängung durch Ziehen grob einstellen.



Achtung!
Vor der Montage alle stromführenden Leitungen vom Stromnetz trennen!

Sento sospeso flat fixe Länge

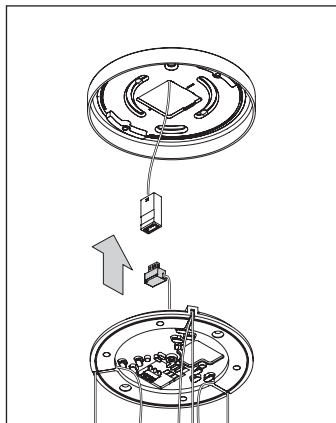

Stecker der Leuchte mit der Buchse des LED-Anschlusskabels verbinden.

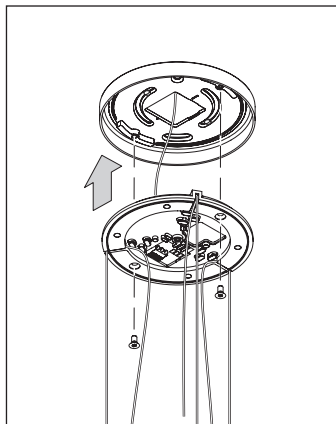

Steckverbindung in die Hohlraum-dose zurückschieben.

Kabelhalterung mit mitgelieferten Schrauben (Inbus) an beide Abstandshalter der Montageplatte schrauben.

Bei mehreren Leuchten auf identische Ausrichtung der Kabelhalterung achten!

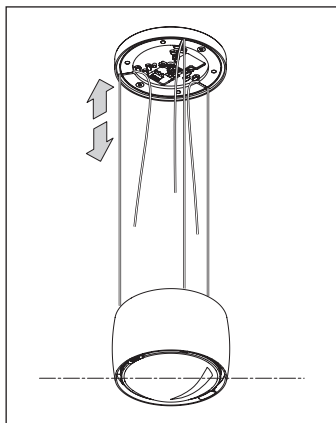

Endgültige Länge der Kabel durch Ziehen einstellen. Dabei darauf achten, dass alle drei Kabel genau gleich lang sind und der head waagrecht hängt.

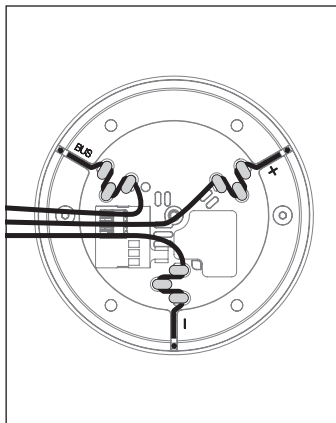

Alle drei losen Kabel nach Schema in die jeweilige Zugentlastung einfädeln.

Sento sospeso flat fixe Länge

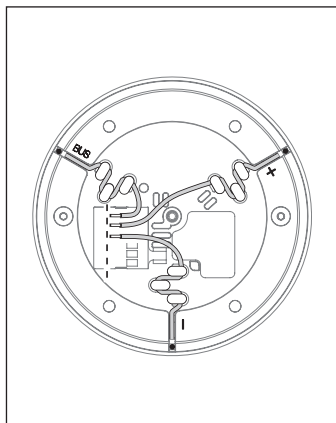

Kabel passend kürzen und an den Enden 6–7 mm abisolieren.

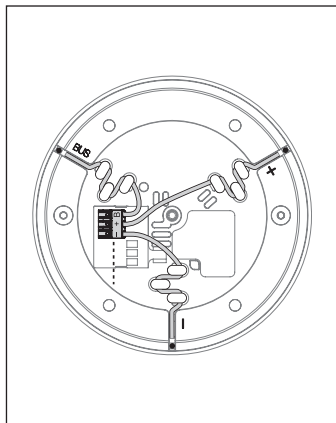

Alle Kabel an die Klemmen anschließen.

Polung beachten!

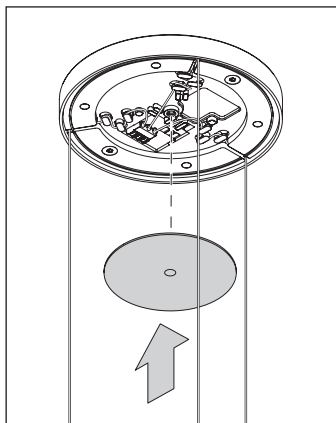

Kabelabdeckung an die Kabelhalterung schrauben.

Darauf achten, dass die Kabel alle flach anliegen.

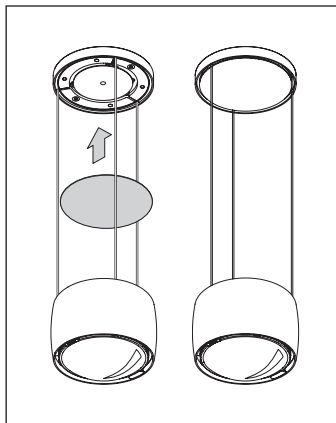

Cover aufsetzen. Es wird magnetisch gehalten.

Die Leuchte ist nun fertig montiert.

Sento sospeso flat fixe Länge

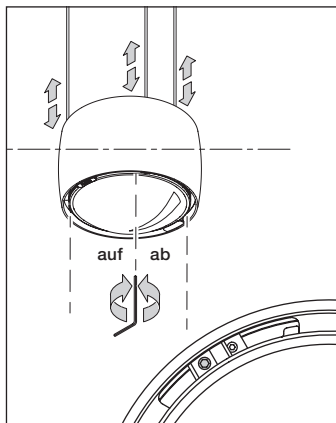

Head waagrecht einstellen

Hängt der head nicht ganz waagrecht, kann er mit beiliegendem Inbusschlüssel ± 5 mm an allen drei Abhängungen nachjustiert werden.



Sento sospeso trimless
fixe Länge

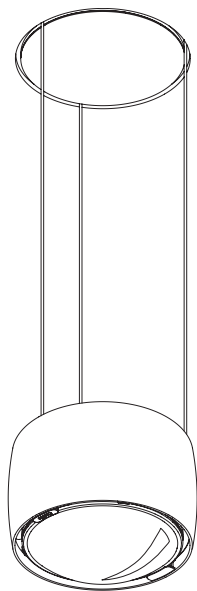



Ausschnitt:
> 250 x 250 mm

Einbauplatte
(Faserzementplatte)
250 x 250 mm
Dicke: 12,5 mm

Distanzring (accessory box)

Kabelhalterung

Kabelabdeckung

Cover

head

Externer
Konverter*

230 V AC
Netzanschluss-
leitung

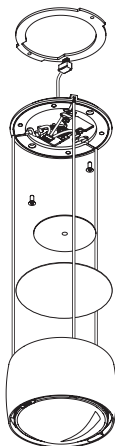

* Externer LED Konverter
(Gleichspannungsquelle)
48 V DC, min. 40 W

Sento sospeso trimless fixe Länge

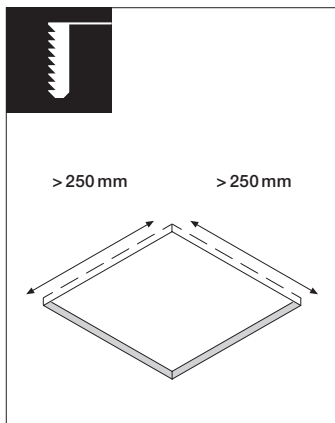

Deckenausschnitt im Format
> 250 x 250 mm herstellen.

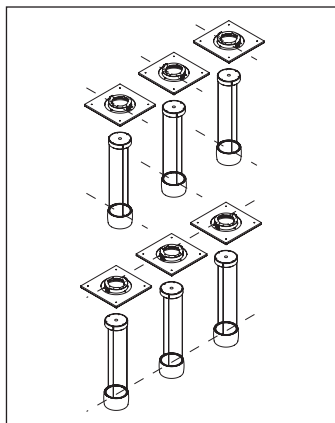

**Richtige Ausrichtung der
Einputzplatte beachten! Die
Ausrichtung der Einputzplatte
bestimmt die späteren Positio-
nen der Abhängekabel!**

**Bei mehreren Leuchten auf
gleiche Ausrichtung achten!**

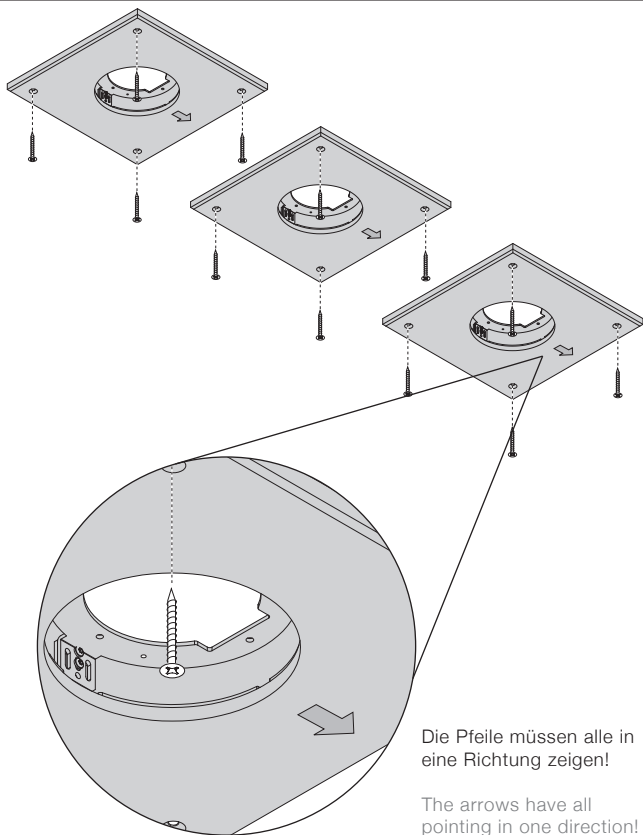

Die Pfeile müssen alle in eine Richtung zeigen!

The arrows have all pointing in one direction!

Sento sospeso trimless fixe Länge

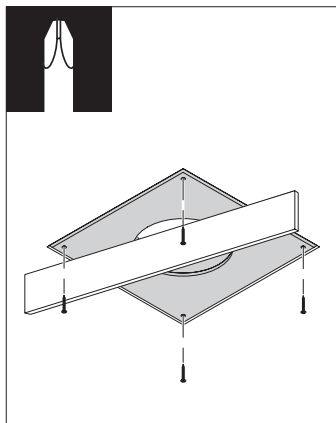

Einputzplatte fachgerecht bündig in der Öffnung montieren. Dazu vorgesehene Bohrlöcher verwenden. Wird die Platte an anderen Stellen fixiert, vor dem Anschrauben vorbohren, um die Einputzplatte nicht zu beschädigen.



Achtung!

Der Hersteller weist ausdrücklich darauf hin, dass eine nicht fachgerecht installierte Einputzplatte herabfallen kann und eine erhebliche Gefahr darstellt!

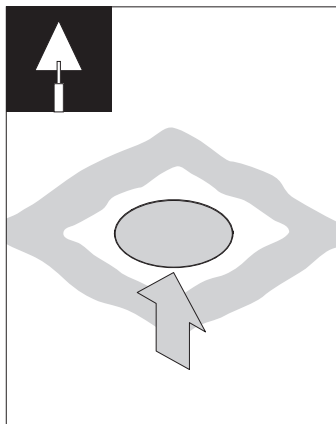

Schutzhaube in die Öffnung einsetzen.

Fugen verputzen.

Darauf achten, dass die Innenseite des Montagerings nicht verschmutzt wird.

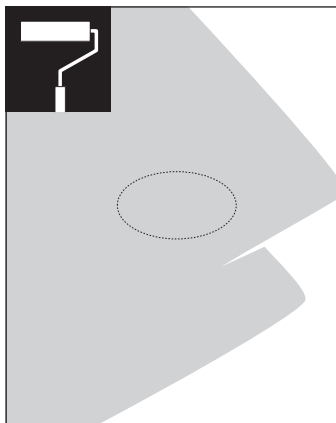

Malarbeiten ausführen.

Darauf achten, dass die Innenseite des Montagerings nicht verschmutzt wird.

Schutzhaube entfernen.

Putz- / Farbreste auf der Innenfläche des Einbaurings ggf. mit feinem Schleifpapier entfernen.



Achtung!
Vor der Montage alle stromführenden Leitungen vom Stromnetz trennen!

Sento sospeso trimless fixe Länge

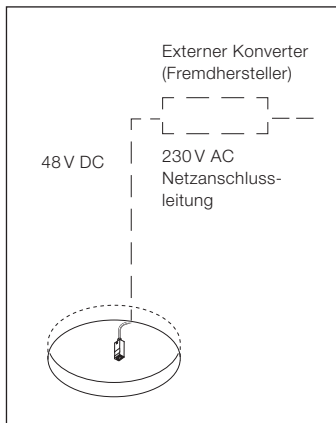

Konverter eines Fremdherstellers anschließen (siehe Beiblatt zum Konverter):

Konverter nach Schema an die Netzleitung anschließen. Kabel mit LED-Buchse an den Konverter anschließen. Technische Hinweise des jeweiligen Herstellers beachten! **Schwarz = Pluspol, Weiß = Minuspol** Buchse des LED Verlängerungskabels durch die Hohlraum- / Einputzdose nach außen führen.

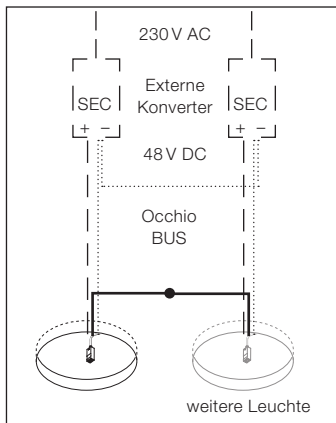

Occhio BUS (optional)

Durch Verbinden der Occhio BUS Kabel ist es möglich, mehrere Leuchten synchron mit »touchless control« zu steuern. Dazu die Einstellung am head auf „DIM“ einstellen.

Die mit BUS gekennzeichneten Kabel mit einer geeigneten Klemme miteinander verbinden. Bei mehreren Convertern müssen die Minuspole (SEC) miteinander verbunden werden. Andere Kabel wie oben angegeben anschließen.

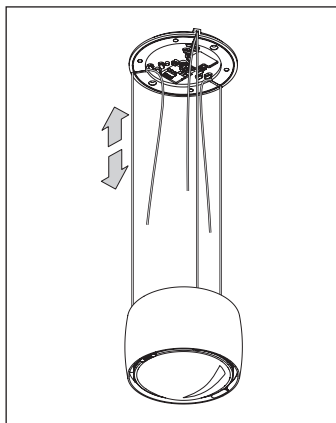

Länge der Abhängung durch Ziehen grob einstellen.

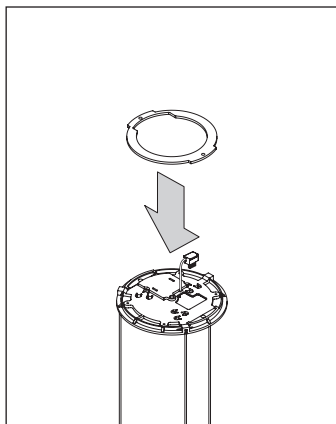

Distanzring bündig auf die Kabelhalterung der Leuchte legen.

Sento sospeso trimless fixe Länge

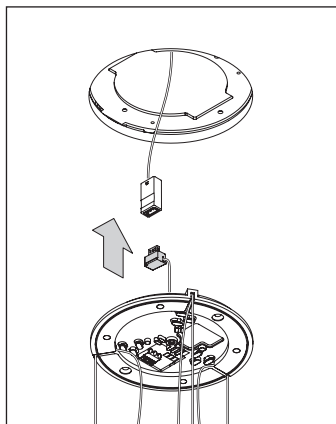

Stecker der Leuchte mit der Buchse des LED-Anschlusskabels verbinden.

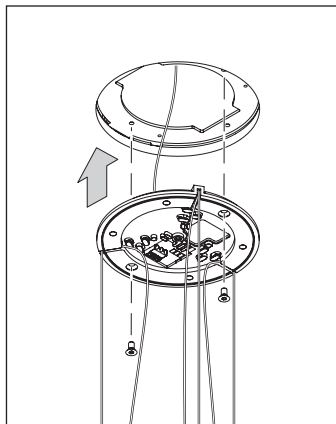

Steckverbindung in den Hohlraum zurückschieben.

Kabelhalterung mit mitgelieferten Schrauben (Inbus) an die Halterung in der Einputzplatte schrauben.

Bei mehreren Leuchten auf identische Ausrichtung der Kabelhalterung achten!

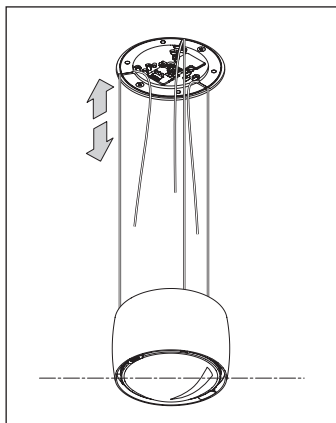

Endgültige Länge der Kabel durch Ziehen einstellen. Dabei darauf achten, dass alle drei Kabel genau gleich lang sind und der head waagrecht hängt.

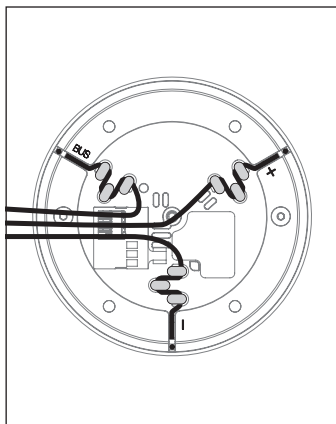

Alle drei losen Kabel nach Schema in die jeweilige Zugentlastung einfädeln.

Sento sospeso trimless fixe Länge

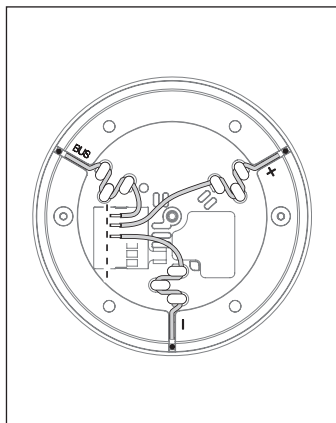

Kabel passend kürzen und an den Enden 6–7 mm abisolieren.

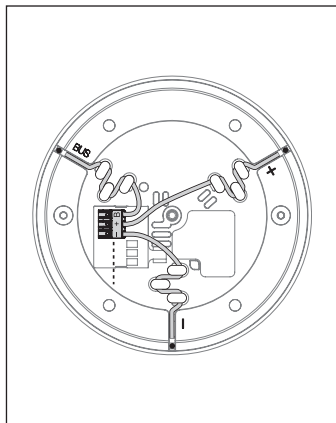

Alle Kabel an die Klemmen anschließen.

Polung beachten!

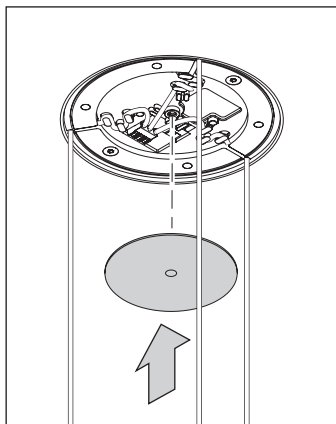

Kabelabdeckung an die Kabelhalterung schrauben.

Darauf achten, dass die Kabel alle flach anliegen.

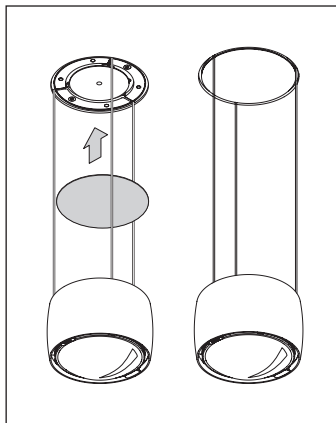

Cover aufsetzen. Es wird magnetisch gehalten.

Die Leuchte ist nun fertig montiert.

Sento sospeso trimless fixe Länge

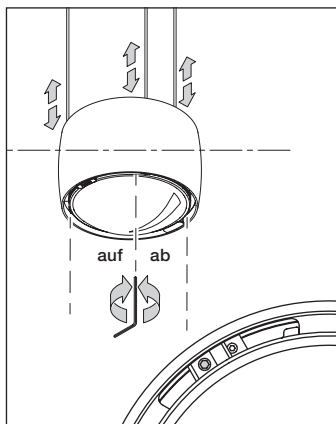

Head waagrecht einstellen

Hängt der head nicht ganz waagrecht, kann er mit beiliegendem Inbusschlüssel $\pm 5\text{mm}$ an allen drei Abhängungen nachjustiert werden.



Anhang

Leuchte nur in abgekühltem Zustand reinigen!

Zur Reinigung der Leuchte ein trockenes Mikrofasertuch oder das Occhio Reinigungsmittel verwenden.

Weitere Fragen beantwortet gerne
Ihr Occhio Fachhändler

www.occhio.de

info@occhio.de

Technische Daten

Technische Daten Leuchte

Artikelbezeichnung	Occhio Sento sospeso
head	ø 123 mm, H 72 mm
up Version mit Höhenverstellung	base ø 108 mm, H 62 mm, Verstellbereich: 500–2000 mm
flat Version mit Höhenverstellung	base ø 108 mm, H 38 mm, Verstellbereich: 500–2000 mm
trimless Version mit Höhenverstellung	Einputzelement 250 x 250 mm, H 12,5 mm Verstellbereich: 500–2000 mm
up Version fixe Länge	base ø 108 mm, H 38 mm, Länge max. 3500 mm
flat Version fixe Länge	base ø 108 mm, H 15 mm, Länge max. 3500 mm
trimless Version fixe Länge	Einputzelement 250 x 250 mm, H 12,5 mm Länge max. 3500 mm
Schutzklasse	up Versionen: 2; flat / trimless Versionen: 3
Anschluss	up Versionen: 230 V AC, 50 Hz flat / trimless Versionen: 48 V DC, min. 40 W
Vorschaltgerät	up Versionen: integriert flat / trimless Versionen: extern
Dimmung	über im Kopf integrierten »touchless Sensor« oder: up Versionen: per Phasenabschnittdimmer oder Occhio air (Liste kompatibler Dimmer: www.occhio.de/dim , Phasenabschnittdimmer nicht kombinierbar mit »touchless control« und Occhio air) flat Version: mit geeignetem Vorschaltgerät

Technische Daten Leuchte

Material	Aluminium, Stahl verchromt, lackiert oder eloxiert, Kunststoff, Faserzementplatte, Glas, optischer Kunststoff
LED-Leistung	32 W (26 W head chrom glanz)
Zulässige Betriebsbedingung	max. 30°C nur im Innenbereich betreiben
Prüfzeichen	IP 20     up:  flat/trimless: 

Technische Daten Leuchtmittel

Leuchtmittel	Occhio LED
Ausführung	LED-Chip (wechselbar)
Lebensdauer	> 50.000 h
Energieeffizienzklasse – EEK	A+ / A

Entsorgung

Bei örtlicher Entsorgungsstelle entsorgen. Sento sospeso ist recyclebar; RoHS-konform. **Nicht in den Hausmüll geben!**

Occhio

Sento sospeso

Mounting instructions

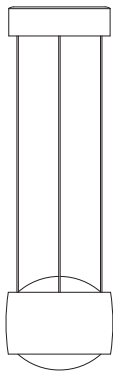

up
flat
trimless

Safety precautions

Read through the mounting/ use instructions carefully before installing the luminaire. Follow the safety precautions in these instructions closely and keep the instructions in a safe place.



This symbol warns you of a dangerous situation which could lead to serious injury or even death if the instructions are not observed. It also draws your attention to possible material damage and provides other important information in connection with this product.



The assembly and installation of electrical components must be carried out only by qualified personnel. Repairs must be carried out only by authorised, qualified personnel or the manufacturer. Before performing any work on the spotlight (installation, changing the light source, cleaning, etc.), it must be disconnected from the mains supply.



This symbol draws your attention to situations in which you could look directly into the light of the LED. This may cause an after-image effect and may result in damage to the eyes if you look at the light directly for prolonged periods.



Maintain the minimum safety distance from flammable materials: 20 cm!



This symbol warns you of hot surfaces, which could cause burns if touched.

Caution: When used for prolonged periods, the surface of the spotlight can become hot. Before performing any work on the spotlight (fitting the spotlight, changing the light source or insert, etc.), always switch the spotlight off and let it cool for at least 30 minutes.

Product description

LED suspended luminaire with double-sided light emission. Light output 32 W (26 W on shiny chrome version). Ratio of up- and downlight is freely adjustable. Lighting effect can be changed through optional inserts.

up version with height adjustment

Continuous height adjustment, high base incl. power supply unit (converter) for mounting on a solid ceiling; connection to 230V. Externally dimmable by trailing-edge phase-cut dimmer or by gesture-controlled »touchless control« on the head.

flat version with height adjustment

Continuous height adjustment, flat base for mounting on a hollow ceiling box; connection to an external constant-voltage source (converter). Externally dimmable (depending on power supply unit) or by gesture-controlled »touchless control« on the head.

trimless version with height adjustment

Continuous height adjustment incl. ceiling element for flush mounting in a hollow ceiling. Connection to an external constant-voltage source (converter). Externally dimmable (depending on power supply unit) or by gesture-controlled »touchless control« on the head.

up version fixed length

Permanently adjustable height during fitting and a high base incl. power supply unit (converter) for mounting on a solid ceiling; connection to 230V. Externally dimmable by trailing-edge phase-cut dimmer or by gesture-controlled »touchless control« on the head.

flat version fixed length

Permanently adjustable height during fitting, flat base for mounting on a cavity box; connection to an external constant-voltage source (converter). Externally dimmable (depending on power supply unit) or by gesture-controlled „touchless control“ on the head.

trimless version fixed length

Permanently adjustable height during fitting incl. ceiling element for flush mounting in a hollow ceiling. Connection to an external constant-voltage source (converter). Externally dimmable (depending on power supply unit) or by gesture-controlled »touchless control« on the head.

Assembling the head

Assembling the head (inserts)



Lens



Diffuser glass

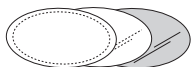

Soft-edge glass,
satinised glass or
colour filter (optional)



Colour filter (optional)

head

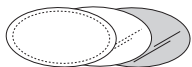
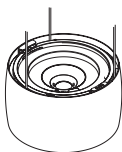

Soft-edge glass,
satinised glass or
colour filter (optional)

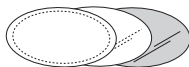

Soft-edge glass,
satinised glass or
colour filter (optional)



Lens

Version D



Lens

Version E



Assembling the head (inserts)

Colour filter/diffuser glass

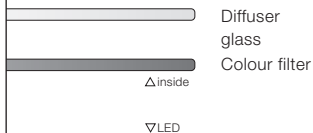

Colour filter/lens

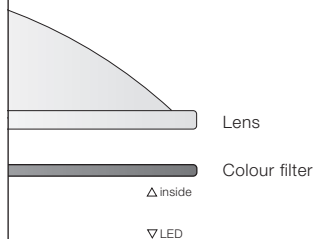

Soft-edge glass/lens

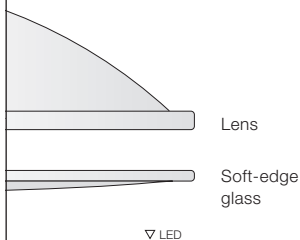

Caution: When used for prolonged periods, the surface of the spotlight can become hot. Before performing any work on the spotlight, always switch it off and allow it to cool down for at least 30 minutes.



Caution: Do not look directly into the LED when it is on. This may cause an after-image effect and may result in damage to the eyes if you look at the light directly for prolonged periods. Do not touch the LED. It may be damaged as a result.

Assembling the head (inserts)

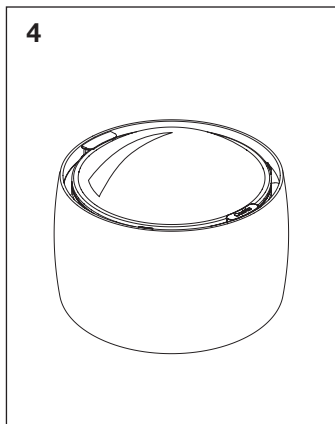
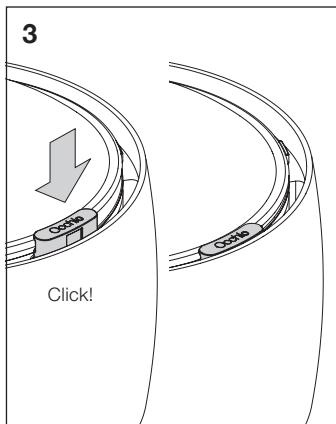
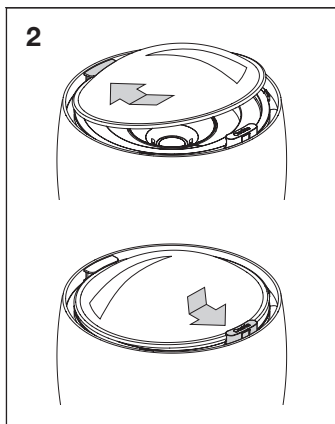
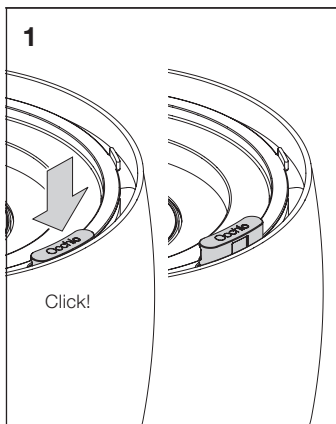

Assembling the spot lens (optional)

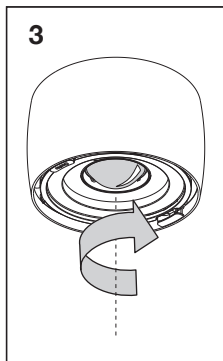
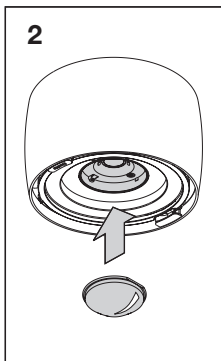
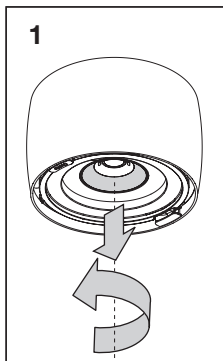

Removing the spot lens

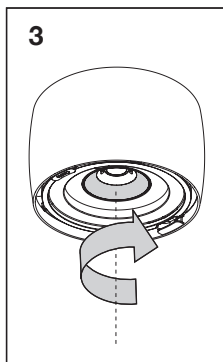
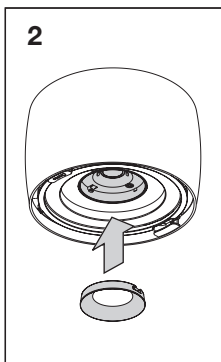
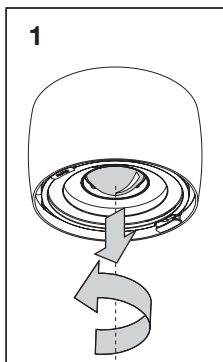



touchless control
up/down fading

Setting the head to DIM

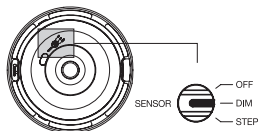

- OFF** Switch and dim externally
- DIM** »touchless control«
»touchless fading«
Touchless control
- STEP** »up / down preset«
Presets the lighting conditions of the up-/downlight Switch and dim externally

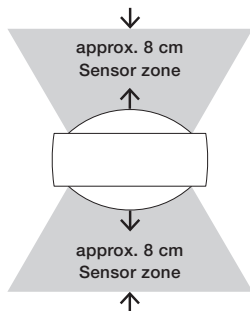

»touchless control« operation

ON/OFF

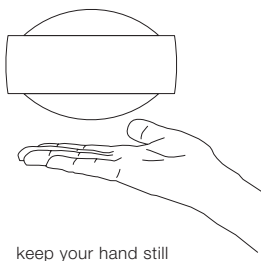
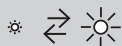
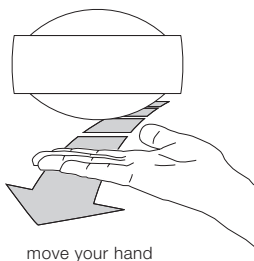

»touchless fading« operation

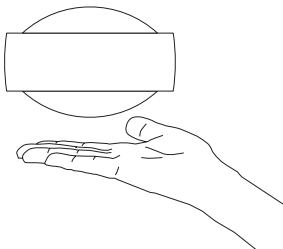

keep your hand still for a time

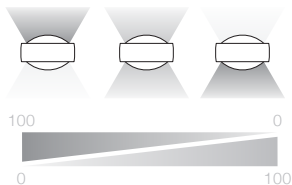

Moves the maximum brightness to one side of the light emission

Coupling/decoupling the up- and downlight

(de)coupling

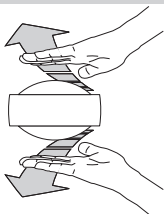

move hands simultaneously
The luminaire flashes to confirm

ON/OFF

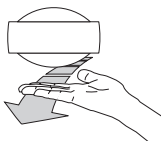

move your hand
Switches both sides
on/off at the same time

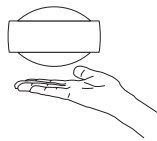
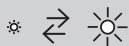

keep your hand still
Dims both sides
at the same time



up/down
preset

Setting the head to STEP

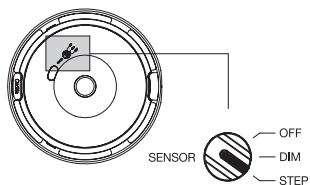

OFF Switch and dim externally

DIM »touchless control«
»touchless fading«
Touchless control

STEP »up / down preset«
Presets the lighting conditions of the up-/downlight Switch and dim externally

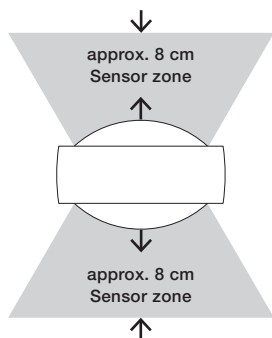

Adjust and save up/down ratio

1

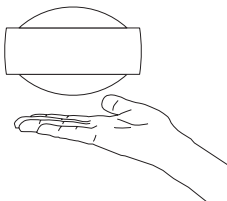

Hold for 10 seconds

Luminaire is unlocked
and flashes to confirm

2

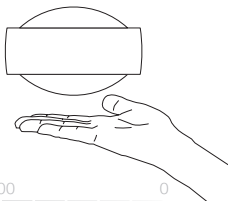

Keep your hand still for a time

Sets the lighting conditions in 5 stages

3

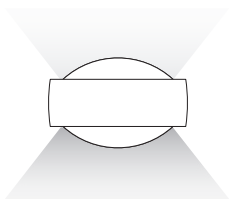

Wait for 5 minutes or switch
on/off at the mains

The setting is now saved

4

ON/OFF – DIM

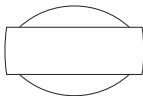

Switch/
dimmer*

Switching and dimming

The saved setting for the luminaire
remains unchanged

Steuerung mit
der Occhio air
App (optional)

Control using
the Occhio air
app (optional)

Steuerung mit der Occhio air App (optional)

Control using the Occhio air app (optional)

Quick guide

Die Occhio air Produkte lassen sich mit der Occhio air App einrichten und steuern.

App installieren, App öffnen und angeschlossene Leuchten einrichten.

Occhio air products can be set up and controlled using the Occhio air app.

Install App, open App and set up connected luminaires.



Occhio air tutorials

www.occhio.de/air-tutorials

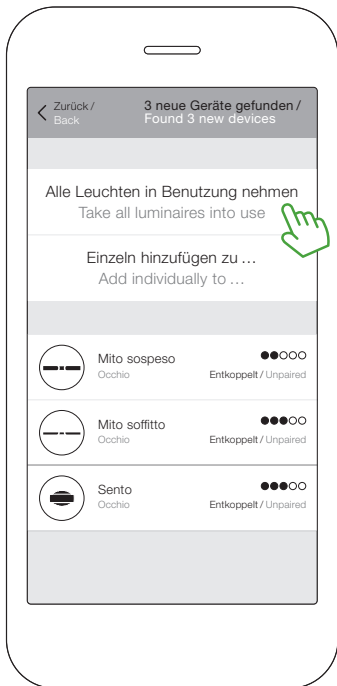

Ein Netzwerk (mein Netzwerk) wird autom. erstellt.

A network (my network) is autom. created.

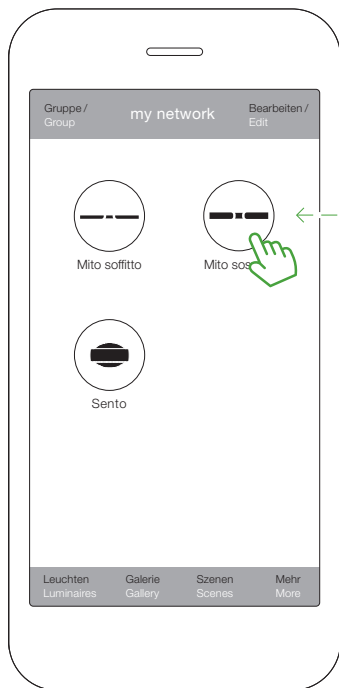

Steuerungsgesten Control gestures

on / off
on / off



antippen
tap

dimmen
dim



wischen
swipe

up / down
faden *



wischen
swipe

color tune **



halten
hold



wischen
swipe

* Leuchten mit beidseitigem Lichtaustritt /
luminaires with light emission on both sides

** Mito

Und so werden die Leuchten gesteuert.
And so the luminaires are controlled.

Steuerung mit der Occhio air App (optional) Control using the Occhio air app (optional)

Nutzung auf mehreren Geräten

Use on several devices

Optional können Sie nun ihr
erstelltes Netzwerk (mein
Netzwerk) mit Anderen teilen.

Optionally, you can now share
your created network (my
network) with others.

1. Netzwerknamen
vergeben

1. Assign name

Occhio air tutorials

www.occhio.de/air-tutorials

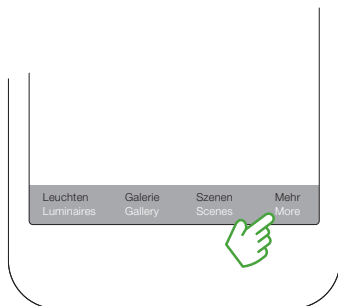

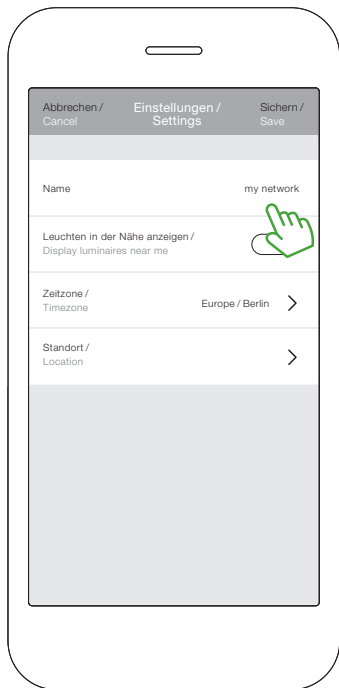

Netzwerkconfiguration → Netzwerkeinstellungen → Namen eingeben → Sichern
Network setup → Network settings → enter name → save

Steuerung mit der Occhio air App (optional) Control using the Occhio air app (optional)

Netzwerk freigeben
und schützen

Share and protect the
network

Occhio air tutorials
www.occhio.de/air-tutorials

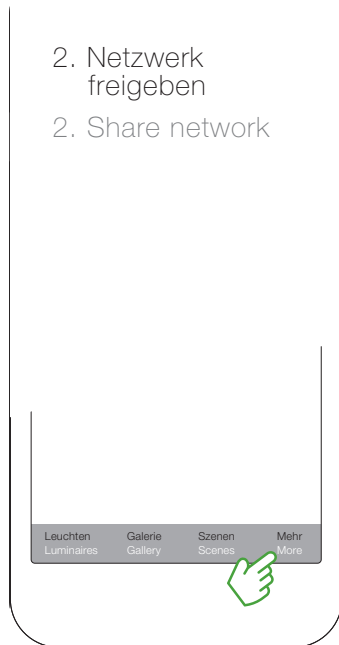

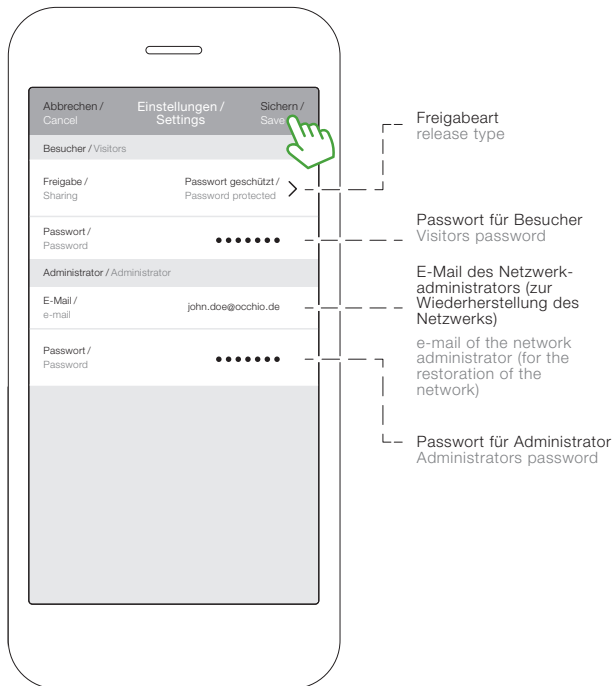

Netzwerkconfiguration → Freigabeoptionen → Passwort geschützt → Sichern
 Network setup → Sharing settings → Password protected → save

Steuerung mit
dem Occhio air
controller
(optional)

Control using
the Occhio air
controller
(optional)

Steuerung mit dem Occhio air controller (optional)

Control using the Occhio air controller (optional)

Occhio air controller

Intuitiv bedienbare Fernbedienung mit vier programmierbaren Tasten (Einrichtung via Occhio air App). Unabhängig von der App können einzelne Leuchten, Gruppen und Szenen gesteuert werden. Optional mit Wandhalterung erhältlich.

Maximaler Bedienkomfort und umfassende Steuerung via Bluetooth 4.0 (Bluetooth Low Energy). Schalten, dimmen, faden, color tune von einzelnen Leuchten, Gruppen und Szenen.

Occhio air controller

Intuitive remote control with four programmable buttons (setup via Occhio air app). Individual luminaires, groups and scenes can be controlled regardless of the app. Available with optional wall mount.

Maximum ease of use and total control via Bluetooth 4.0 (Bluetooth low energy). Switching, dimming, fading, color tune of individual luminaires, groups and scenes.



Zum Einrichten des Occhio air controllers wird die Occhio air App benötigt. Eine Video-Kurzanleitung kann unter: www.occhio.de/air-tutorials aufgerufen werden.

To set up the Occhio air controller, the Occhio air app is required. A video quick start guide can be called up at www.occhio.de/air-tutorials.

schalten/switch



⏏ - ☰ einzelne Leuchten, Gruppen, oder Szenen schalten

⏏ - ☰ switch individual luminaires, groups or scenes

dimmen/dim



⊕ - ☰ einzelne Leuchten, Gruppen, oder Szenen dimmen

⊕ - ☰ dims individual luminaires, groups or scenes

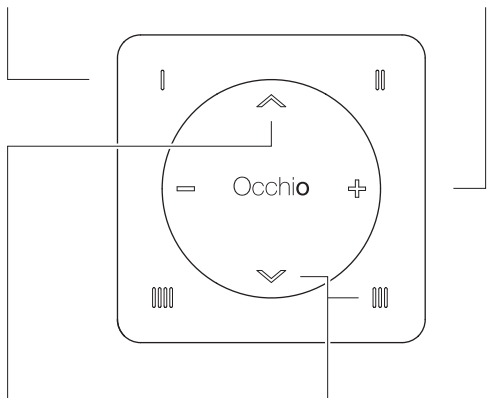

faden*



∧ ∨ einzelne Leuchten, Gruppen oder Szenen faden (up/down Verhältnis ändern)

∧ ∨ fades individual luminaires, groups or scenes (change up/down relation)

color tune**

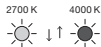

⏏ - ☰ and ∧ ∨ Farbtemperatur einzelner Leuchten, Gruppen oder Szenen einstellen

⏏ - ☰ and ∧ ∨ adjust color temperature of individual luminaires, groups or scenes

* Leuchten mit beidseitigem Lichtaustritt / luminaires with light emission on both sides ** Mito

Fitting the luminaire



Sento sospeso up with height adjustment 134
for solid ceilings, power supply unit integrated



Sento sospeso flat with height adjustment 142
for hollow ceiling/plastering box, external power supply unit



Sento sospeso trimless with height adjustment 150
with mounting plate, external power supply unit



Sento sospeso up fixed length 160
for solid ceilings, power supply unit integrated



Sento sospeso flat fixed length 170
for hollow ceiling/plastering box, external power supply unit



Sento sospeso trimless fixed length 180
with mounting plate, external power supply unit

Sento sospeso up
with height adjustment

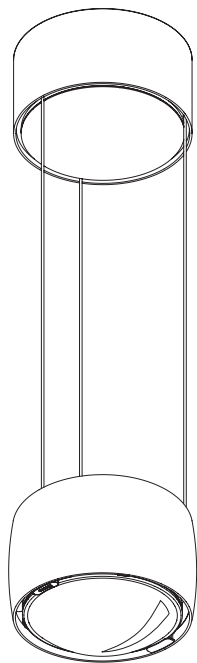



230 V AC
mains cable



Canopy

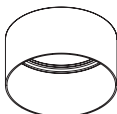

Mounting plate

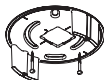

Occhio converter

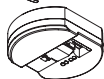

Mounting ring

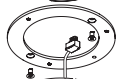

Cable winder
with plug



Cover



head

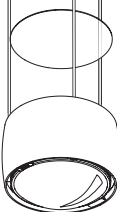

Sento sospeso up with height adjustment

230 V AC
mains cable

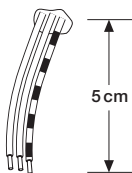

Cut the mains cable to a length of 5 cm and strip the insulation from the ends.

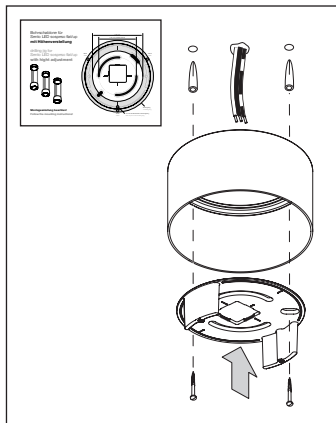

Determine the positions for drilled holes using the drilling template provided. The orientation of the mounting plate determines the subsequent positions of the suspension cables. When installing more than one luminaire, ensure that they have the same orientation. **Check the routing of the power cables.** Drill two 6 mm diameter holes, push in the rawlplugs so that they lie flush and screw on the canopy with the mounting plate (screws and rawlplugs are included in the scope of delivery). Ensure that the screws finish flush with the mounting plate.

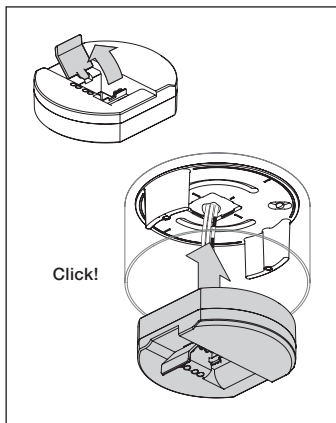

Using a screwdriver, open the flap in the middle of the converter.

Lock the converter into the mounting plate so that it is fitted flush.

At the same time, guide the ends of the mains cable through the converter opening.

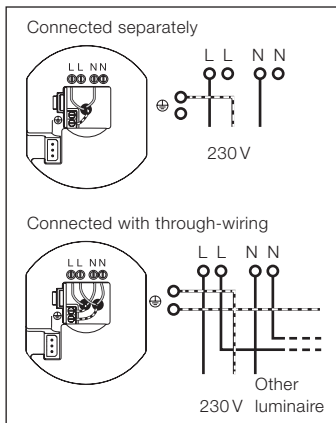

Connect the ends of the mains cable to the converter terminals in accordance with the diagram.



Caution!
Before fitting, disconnect all current-carrying lines from the mains supply.

Sento sospeso up with height adjustment

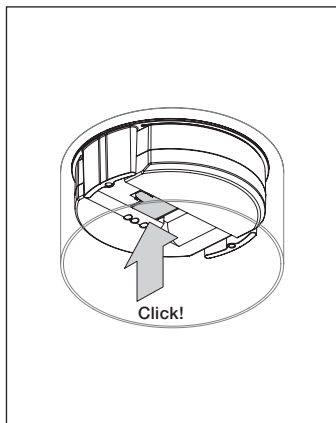

Close the flap of the converter.

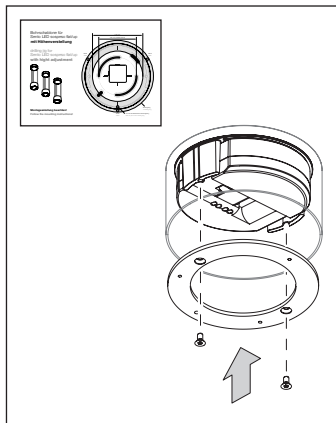

Screw the mounting ring onto the two spacers of the mounting plate using the screws (Allen) provided.

Ensure the correct orientation of the mounting ring (see drilling template).

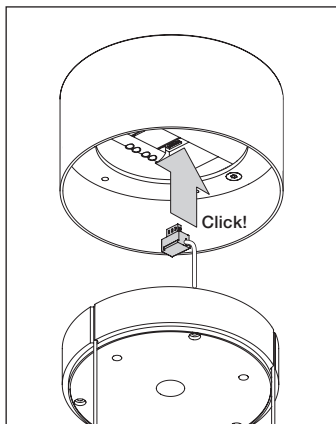

Insert the luminaire's plug into one of the converter's two sockets (LED 1 or LED 2).

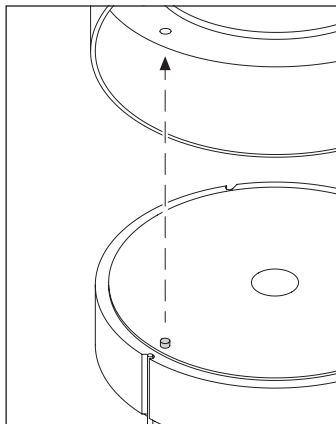

Push the cable winder into the canopy and turn it such that the positioning pin engages in the mounting ring.

Ensure that the cables lie flush in the side grooves.

Sento sospeso up with height adjustment

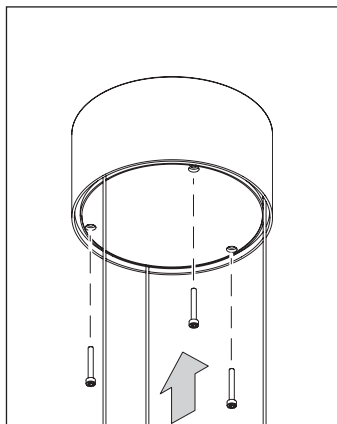

Screw the cable winder to the mounting ring using the screws (Allen) provided.

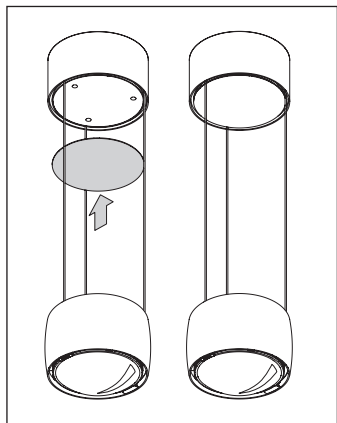

Put the cover in place. It is held in place by magnets.

The luminaire is now fully assembled.

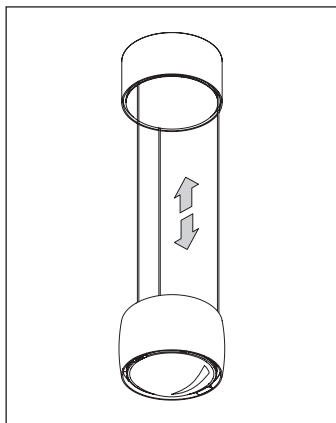

Using the height adjustment

Use both hands to pull the head down or move it up. The cables automatically coil up in the cable winder.

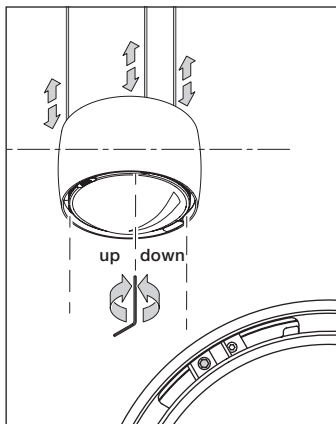

Adjusting the head vertically

First, use both hands to pull the head out vertically as far as possible and move it up again. The cables wind up evenly.

If, after carrying out this procedure, the head still does not hang level, it can be readjusted by ± 5 mm at each of the three suspension cables using the Allen key provided.

Sento sospeso flat
with height adjustment

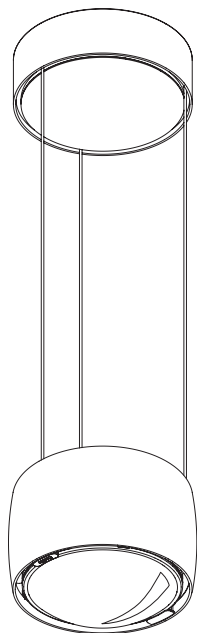



Hollow ceiling box (provided and fitted by customer)

External converter*

230 V AC
Mains cable

Canopy

Mounting plate

Mounting ring

Cable wrap with plug

Cover

head

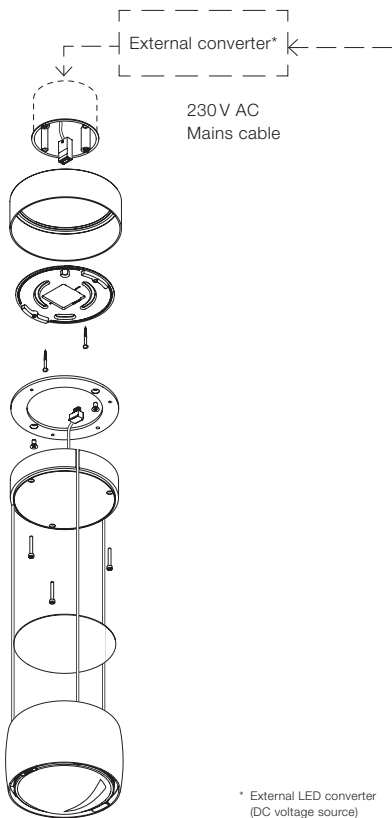

* External LED converter
(DC voltage source)
48V DC, min. 40W

Sento sospeso flat with height adjustment

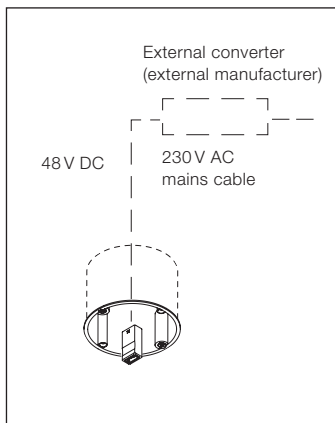

Connecting a converter from an external manufacturer (see supplementary sheet for the converter):

Connect the converter to the mains cable as shown in the wiring diagram. Connect the cable with the LED socket to the converter. Observe the technical instructions of the particular manufacturer.

Black = positive pole, white = negative pole Guide the socket of the LED extension cable to the outside through the hollow ceiling/plastering box.

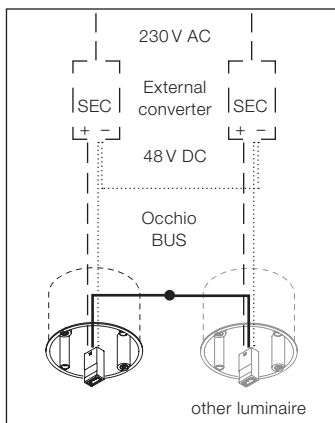

Occhio BUS (optional)

By connecting the Occhio BUS cable, it is possible to control several luminaires synchronously using »touchless control«. To do so, set the head to the „DIM“ setting.

The cables marked with BUS are connected to one another using a suitable terminal. With several converters, the negative poles (SEC) must be connected to each other. Other cables are connected as specified above.

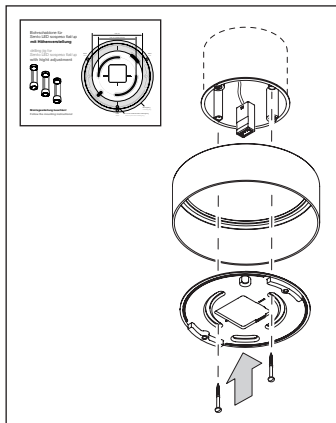

Determine the correct orientation of the mounting plate using the template provided. The orientation of the mounting plate determines the subsequent positions of the suspension cables. When installing more than one luminaire, ensure that they have the same orientation.

Screw the canopy with the mounting plate onto the hollow ceiling box. As you do so, guide the socket of the LED connection cable through the opening. Ensure that the screws finish flush with the mounting plate.

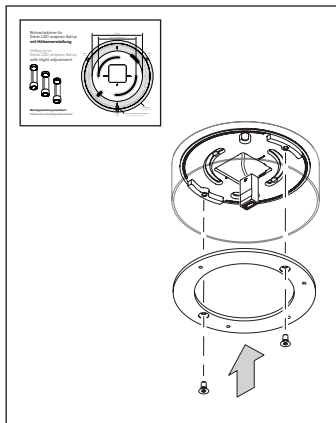

Screw the mounting ring onto the two spacers of the mounting plate using the screws (Allen) provided.

Ensure the correct orientation of the mounting ring (see drilling template).



Caution!
Before fitting, disconnect all current-carrying lines from the mains supply.

Sento sospeso flat with height adjustment

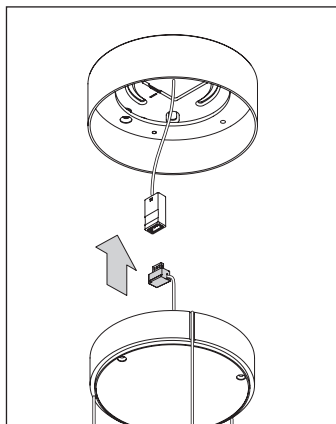

Connect the luminaire to the socket of the LED connection cable.

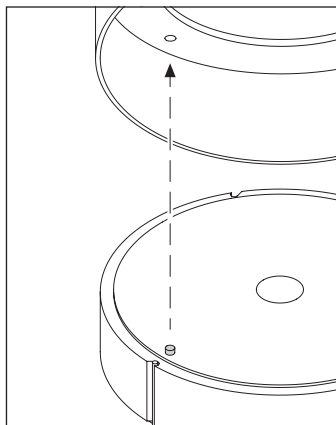

Push the cable winder into the canopy and turn it such that the positioning pin engages in the mounting ring.

Ensure that the cables lie flush in the side grooves.

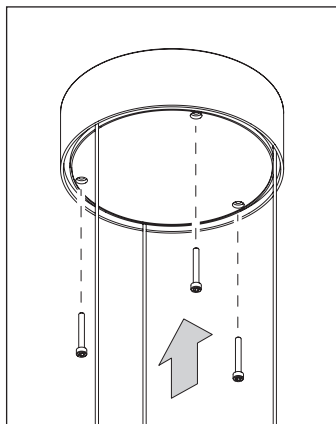

Screw the cable winder to the mounting ring using the screws (Allen) provided.

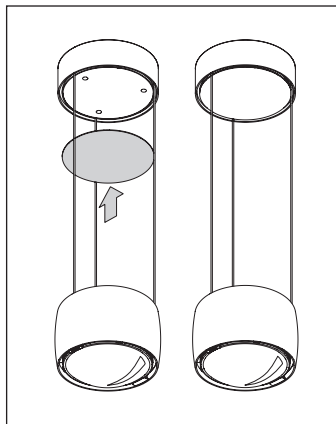

Put the cover in place. It is held in place by magnets.

The luminaire is now fully assembled.

Sento sospeso flat with height adjustment

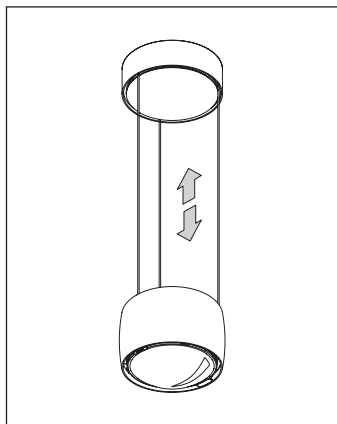

Using the height adjustment

Use both hands to pull the head down or move it up. The cables automatically coil up in the cable winder.

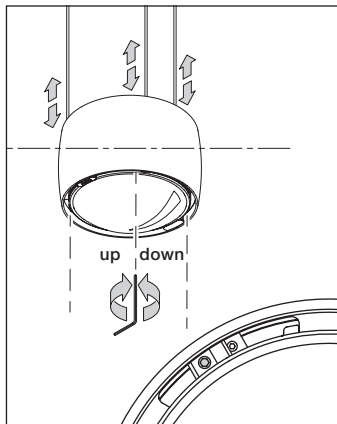

Adjusting the head vertically

First, use both hands to pull the head out vertically as far as possible and move it up again. The cables wind up evenly.

If, after carrying out this procedure, the head still does not hang level, it can be readjusted by ± 5 mm at each of the three suspension cables using the Allen key provided.



Sento sospeso trimless
with height adjustment

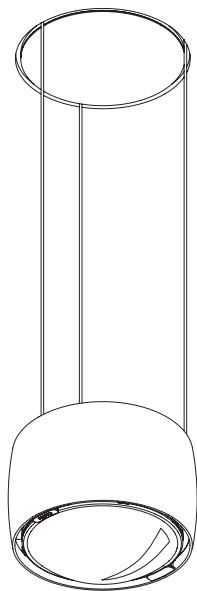



Cut-out:
> 250 x 250 mm

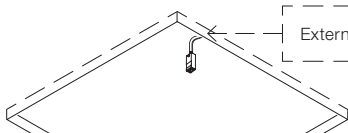

External converter*

230 V AC
Mains cable

Mounting plate
(fibre-cement plate)
250 x 250 mm
Thickness: 12,5 mm

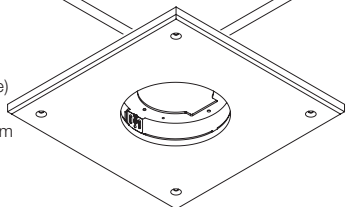

Cable wrap
with plug

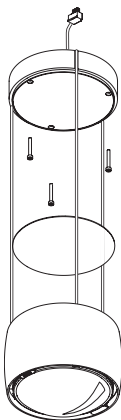

Cover

head

* External LED converter
(DC voltage source) 48V
DC, min. 40W

Sento sospeso trimless with height adjustment

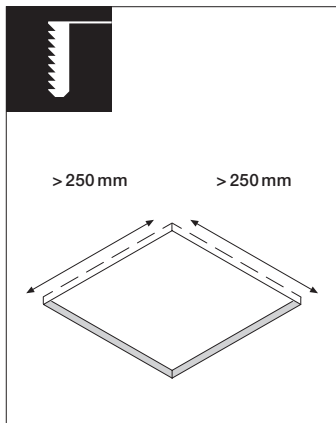

Prepare a ceiling cut-out
> 250 x 250 mm in size.

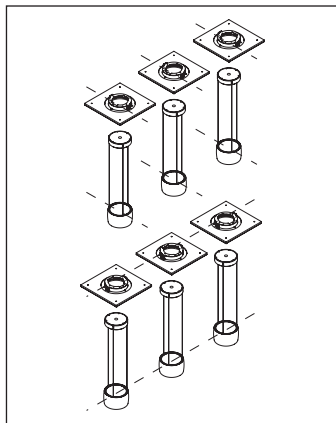

Ensure correct orientation of the
drywalling plate. The orientation
of the drywalling plate determi-
nes the subsequent positions of
the suspension cables.

When installing more than one
luminaire, ensure that they have
the same orientation.

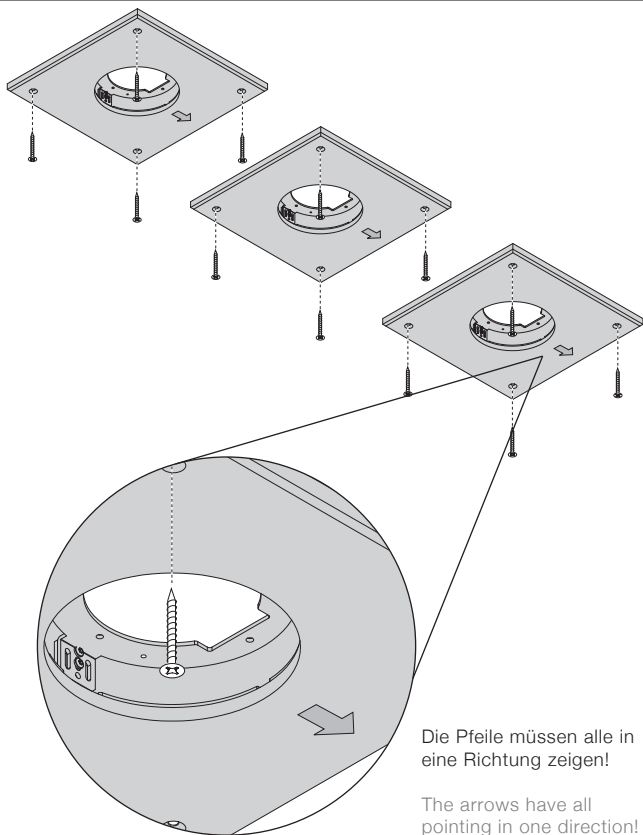

Sento sospeso trimless with height adjustment

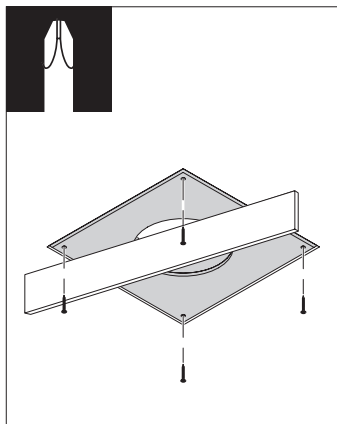

Fit the drywalling plate in the opening correctly so that it is flush. To do so, use the drilled holes provided. If the plate is to be fixed in any other position, pre-drill holes before screwing it in place in order to avoid damaging the drywalling plate.



Caution!

The manufacturer cannot stress strongly enough that if the mounting board has not been properly fitted, it may fall, thereby posing a significant danger.

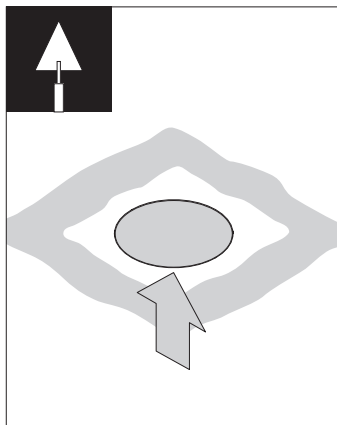

Place the protective cover in the opening.

Plaster over the joins.

Ensure that the inside of the mounting ring is kept clean.

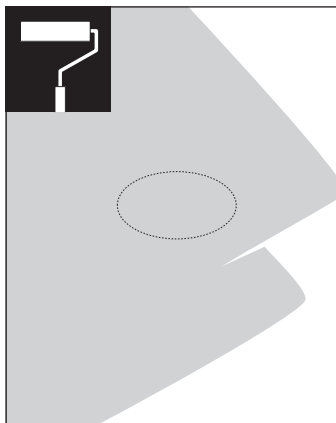

Carry out any painting and decorating work.

Ensure that the inside of the mounting ring is kept clean.

Remove the protective cover.

If necessary, remove any residual plaster/paint from the inside of the mounting ring using fine sandpaper.



Caution!
Before fitting, disconnect all current-carrying lines from the mains supply.

Sento sospeso trimless with height adjustment

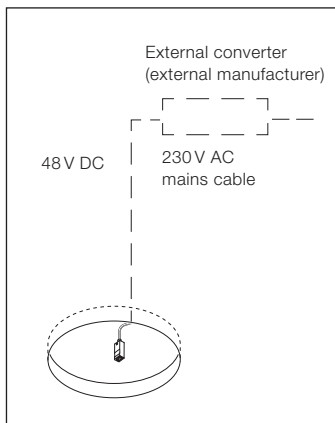

Connecting a converter from an external manufacturer (see supplementary sheet for the converter):

Connect the converter to the mains cable as shown in the wiring diagram. Connect the cable with the LED socket to the converter. Observe the technical instructions of the particular manufacturer.

Black = positive pole, white = negative pole Guide the socket of the LED extension cable to the outside through the hollow ceiling/plastering box.

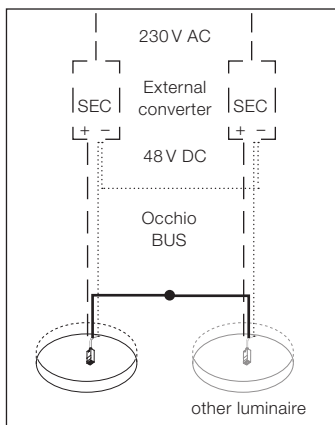

Occhio BUS (optional)

By connecting the Occhio BUS cable, it is possible to control several luminaires synchronously using »touchless control«. To do so, set the head to the „DIM“ setting.

The cables marked with BUS are connected to one another using a suitable terminal. With several converters, the negative poles (SEC) must be connected to each other. Other cables are connected as specified above.

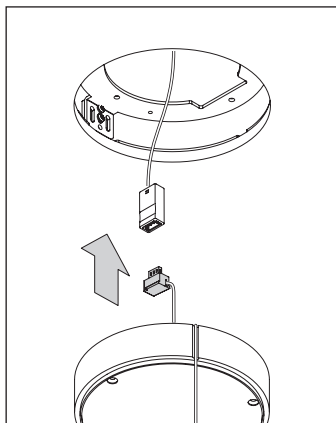

Connect the luminaire to the socket of the LED connection cable.

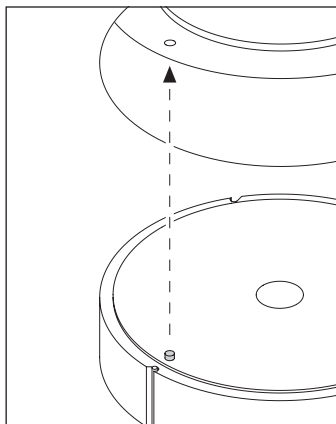

Push the cable winder into the canopy and turn it such that the positioning pin engages in the mounting ring.

Ensure that the cables lie flush in the side grooves.

Sento sospeso trimless with height adjustment

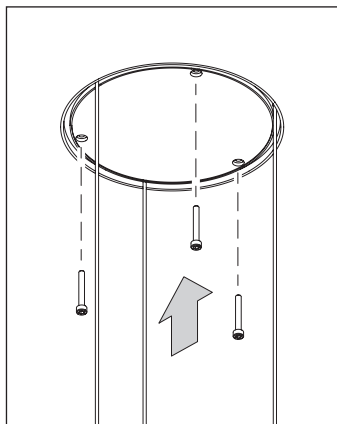

Screw the cable winder to the holder using the screws (Allen) provided.

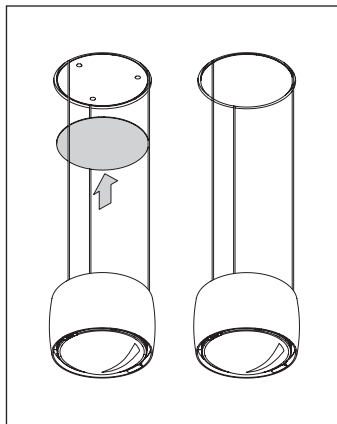

Put the cover in place. It is held in place by magnets.

The luminaire is now fully assembled.

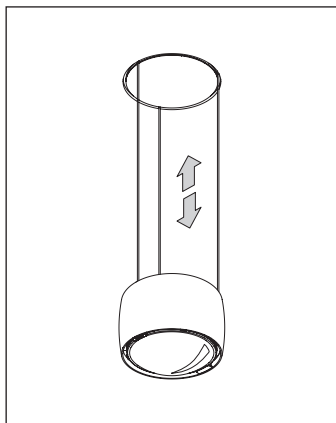

Using the height adjustment

head mit beiden Händen Use both hands to pull the head down or move it up. The cables automatically coil up in the cable winder.

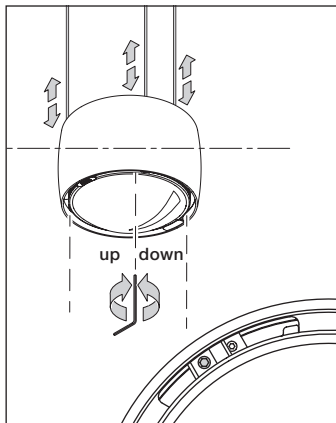

Adjusting the head vertically

First, use both hands to pull the head out vertically as far as possible and move it up again. The cables wind up evenly.

If, after carrying out this procedure, the head still does not hang level, it can be readjusted by ± 5 mm at each of the three suspension cables using the Allen key provided.

Sento sospeso up
fixed length

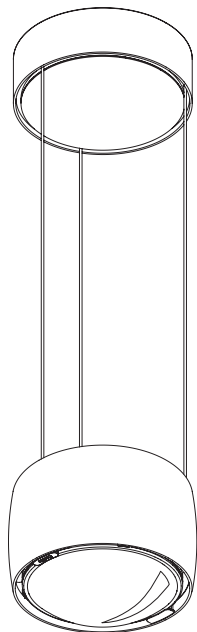



230 V AC
mains cable



Canopy



Mounting plate



Occhio converter



Cable holder



Cable cover

Cover

head

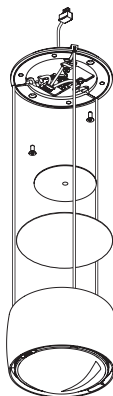

Sento sospeso up fixed length

230 V AC
mains cable

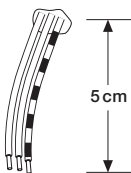

Cut the mains cable to a length of 5 cm and strip the insulation from the ends.

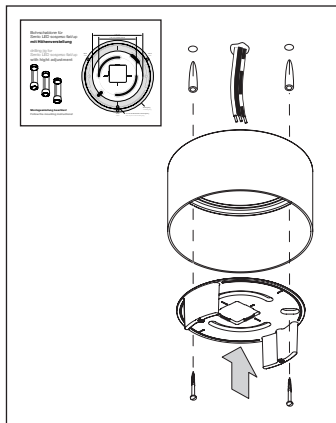

Determine the positions for drilled holes using the drilling template provided. The orientation of the mounting plate determines the subsequent positions of the suspension cables. When installing more than one luminaire, ensure that they have the same orientation. **Check the routing of the power cables.** Drill two 6mm diameter holes, push in the rawlplugs so that they lie flush and screw on the canopy with the mounting plate (screws and rawlplugs are included in the scope of delivery). Ensure that the screws finish flush with the mounting plate.

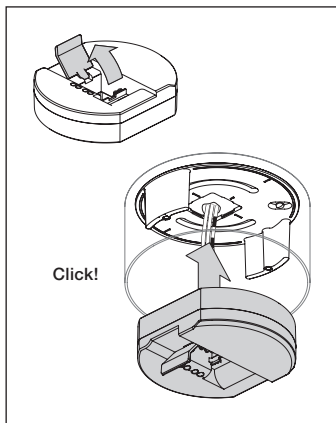

Using a screwdriver, open the flap in the middle of the converter.

Lock the converter into the mounting plate so that it is fitted flush.

At the same time, guide the ends of the mains cable through the converter opening.

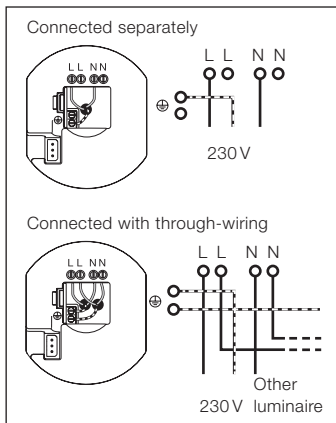

Connect the ends of the mains cable to the converter terminals in accordance with the diagram.



Caution!
Before fitting, disconnect all current-carrying lines from the mains supply.

Sento sospeso up fixed length

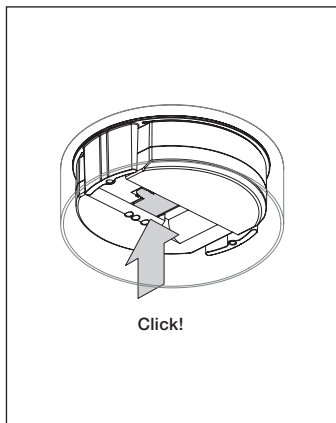

Close the flap of the converter.

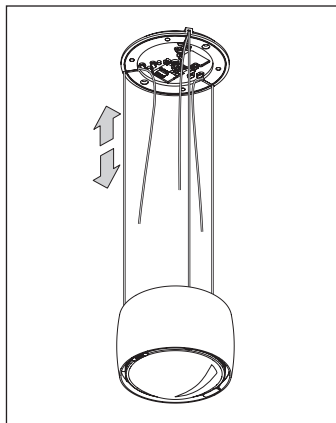

Roughly adjust the length of suspension by pulling the cables.



Insert the luminaire's plug into one of the converter's two sockets (LED 1 or LED 2).

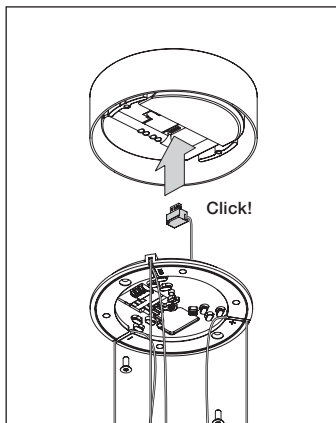

Orient the cable holder as shown in the illustration.

Screw the cable holder onto the two spacers of the mounting plate using the screws (Allen) provided.

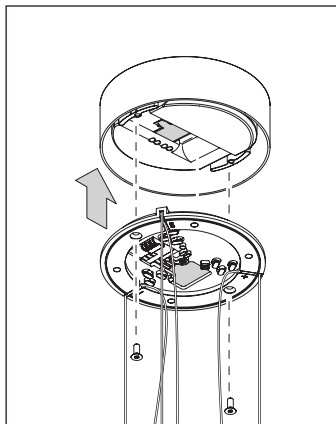

Sento sospeso up fixed length

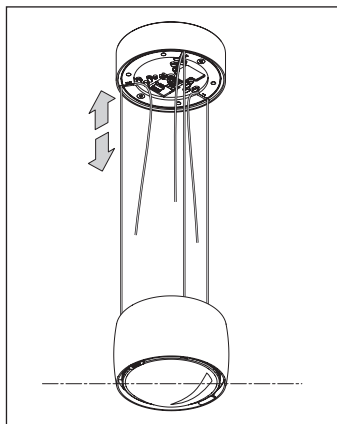

Set the final length of the cables by pulling them. In doing so, ensure that all three cables are exactly the same length and that the head hangs level.

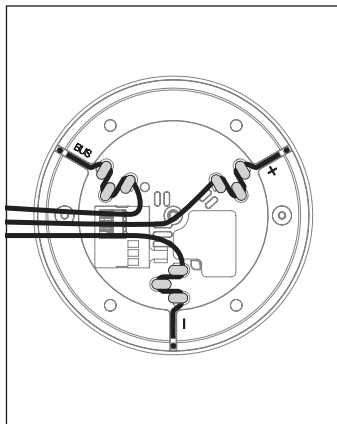

Thread each of the three loose cables into the respective cable grip, in accordance with the diagram.

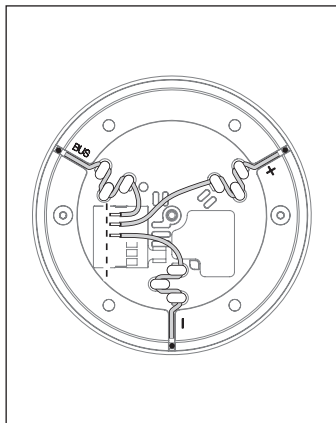

Shorten the cables as necessary and strip 6–7 mm of insulation from the ends.

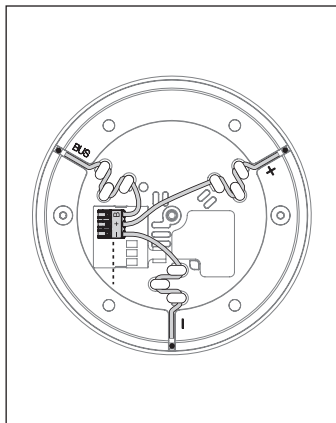

Connect all cables to the terminals.

Correct polarity must be observed.

Sento sospeso up fixed length

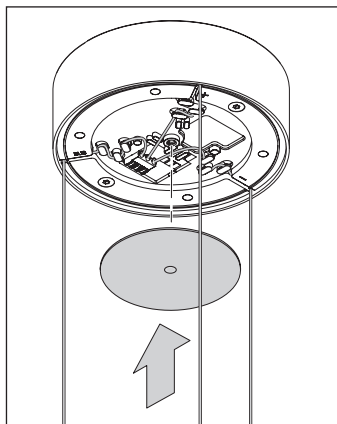

Screw the cable cover onto the cable holder.

Ensure that all cables lie flush.

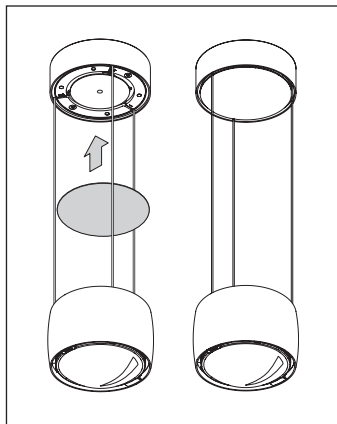

Put the cover in place. It is held in place by magnets.

The luminaire is now fully assembled.

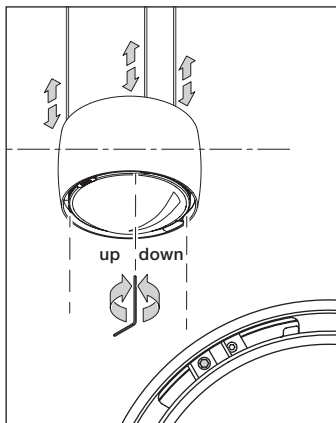

Adjusting the head vertically

If the head does not hang completely level, it can be readjusted by ± 5 mm at each of the three suspension cables using the Allen key provided.

Sento sospeso flat
fixed length

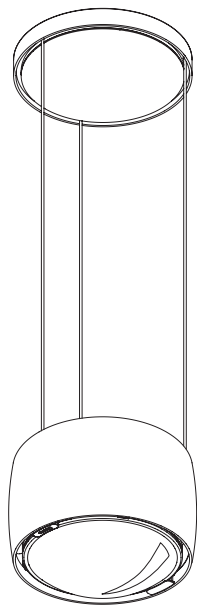



Hollow ceiling box (provided and fitted by customer)

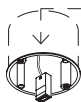

External converter*

230 V AC
Mains cable

Canopy



Mounting plate



Cable holder



Cable cover



Cover

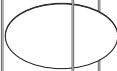

head



* External LED converter
(DC voltage source)
48V DC, min. 40 W

Sento sospeso flat fixed length

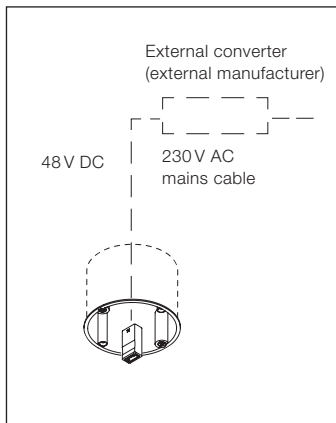

Connecting a converter from an external manufacturer (see supplementary sheet for the converter):

Connect the converter to the mains cable as shown in the wiring diagram. Connect the cable with the LED socket to the converter. Observe the technical instructions of the particular manufacturer.

Black = positive pole, white = negative pole Guide the socket of the LED extension cable to the outside through the hollow ceiling/plastering box.

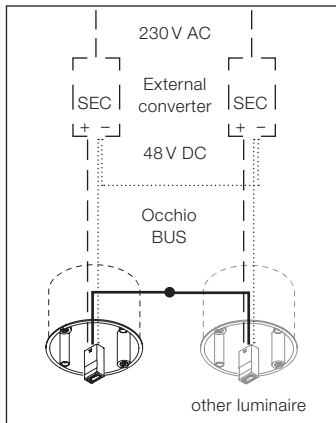

Occhio BUS (optional)

By connecting the Occhio BUS cable, it is possible to control several luminaires synchronously using »touchless control«. To do so, set the head to the „DIM“ setting.

The cables marked with BUS are connected to one another using a suitable terminal. With several converters, the negative poles (SEC) must be connected to each other. Other cables are connected as specified above.

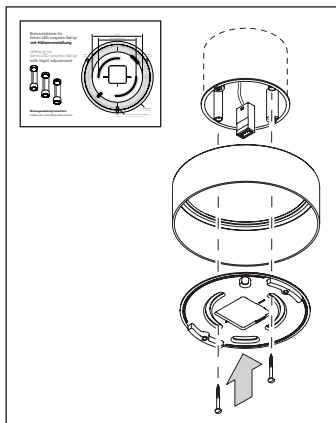

Determine the correct orientation of the mounting plate using the template provided. The orientation of the mounting plate determines the subsequent positions of the suspension cables. When installing more than one luminaire, ensure that they have the same orientation.

Screw the canopy with the mounting plate onto the hollow ceiling box. As you do so, guide the socket of the LED connection cable through the opening. Ensure that the screws finish flush with the mounting plate.

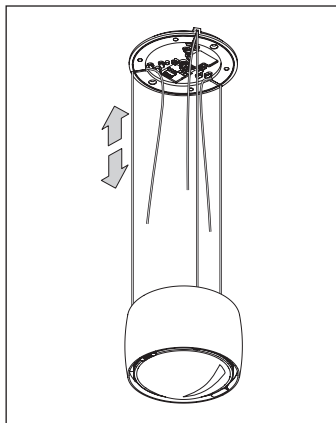

Roughly adjust the length of suspension by pulling the suspension cables.



Caution!
Before fitting, disconnect all current-carrying lines from the mains supply.

Sento sospeso flat fixed length

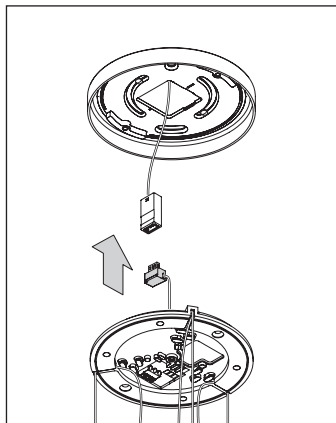

Connect the luminaire to the socket of the LED connection cable.

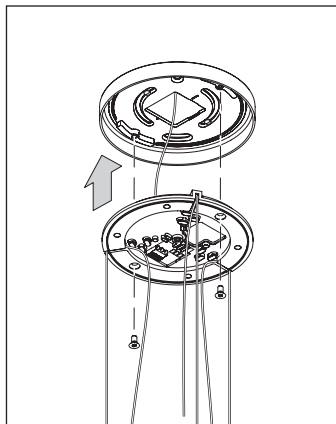

Push the plug connection back into the hollow ceiling box.

Screw the cable holder onto the two spacers of the mounting plate using the screws (Allen) provided.

When installing more than one luminaire, ensure that the cable holders have the same orientation.

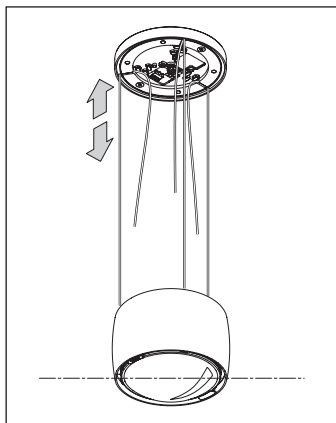

Set the final length of the cables by pulling them. In doing so, ensure that all three cables are exactly the same length and that the head hangs level.

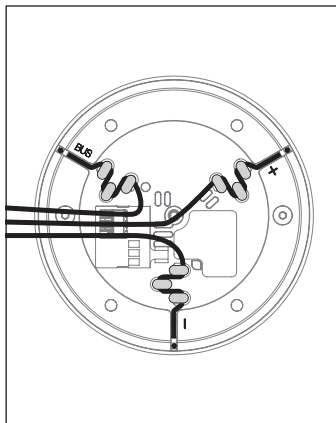

Thread each of the three loose cables into the respective cable grip, in accordance with the diagram.

Sento sospeso flat fixed length

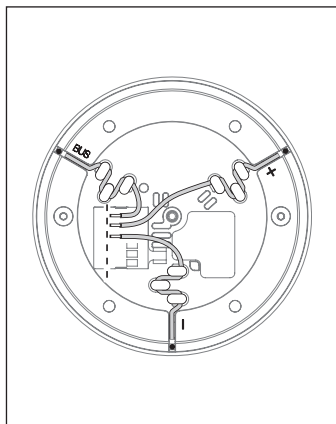

Shorten the cables as necessary and strip 6–7 mm of insulation from the ends.

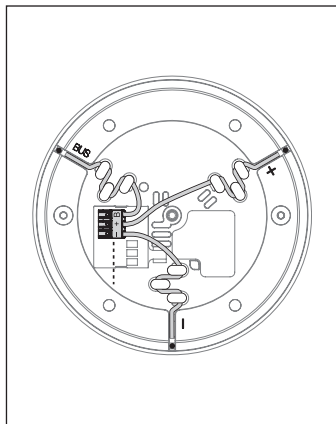

Connect all cables to the terminals.

Correct polarity must be observed.

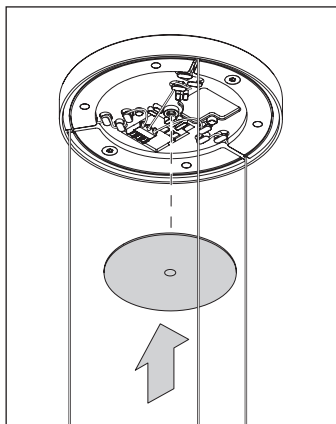

Screw the cable cover onto the cable holder.

Ensure that all cables lie flush.

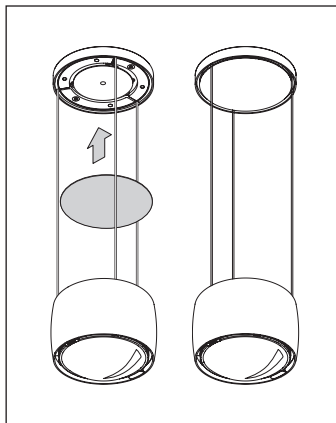

Put the cover in place. It is held in place by magnets.

The luminaire is now fully assembled.

Sento sospeso flat fixed length

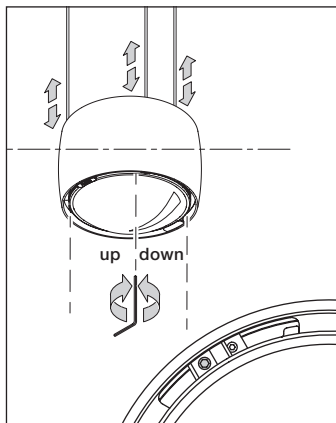

Adjusting the head vertically

If the head does not hang completely level, it can be readjusted by ± 5 mm at each of the three suspension cables using the Allen key provided.



Sento sospeso trimless
fixed length

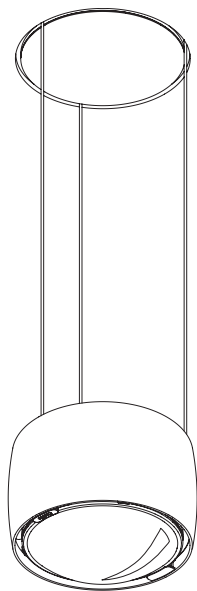



Cut-out:
> 250 x 250 mm

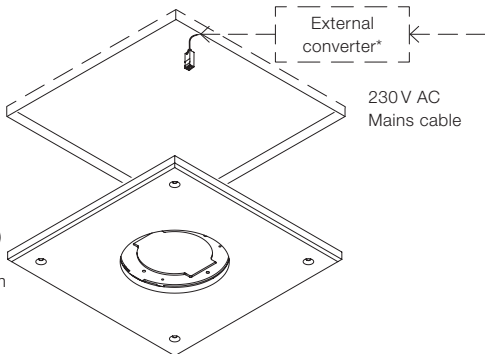

Mounting plate
(fibre-cement plate)
250 x 250 mm
Thickness: 12,5 mm

Spacing ring (accessory box)

Cable holder

Cable cover

Cover

head

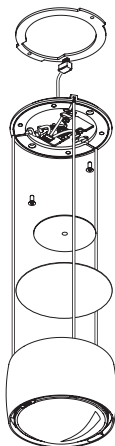

* External LED converter
(DC voltage source)
48 V DC, min. 40 W

Sento sospeso trimless fixed length

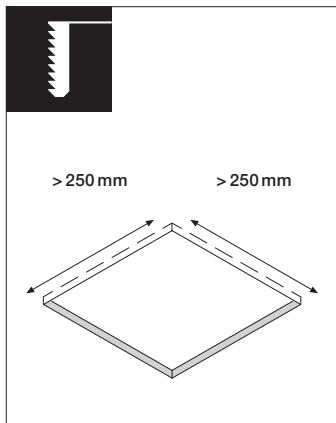

Prepare a ceiling cut-out
> 250 x 250 mm in size.

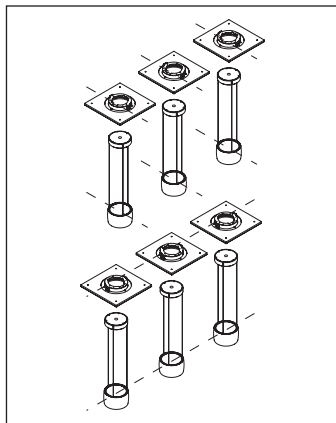

Ensure correct orientation of the
drywalling plate. The orientation
of the drywalling plate determi-
nes the subsequent positions of
the suspension cables.

When installing more than one
luminaire, ensure that they have
the same orientation.

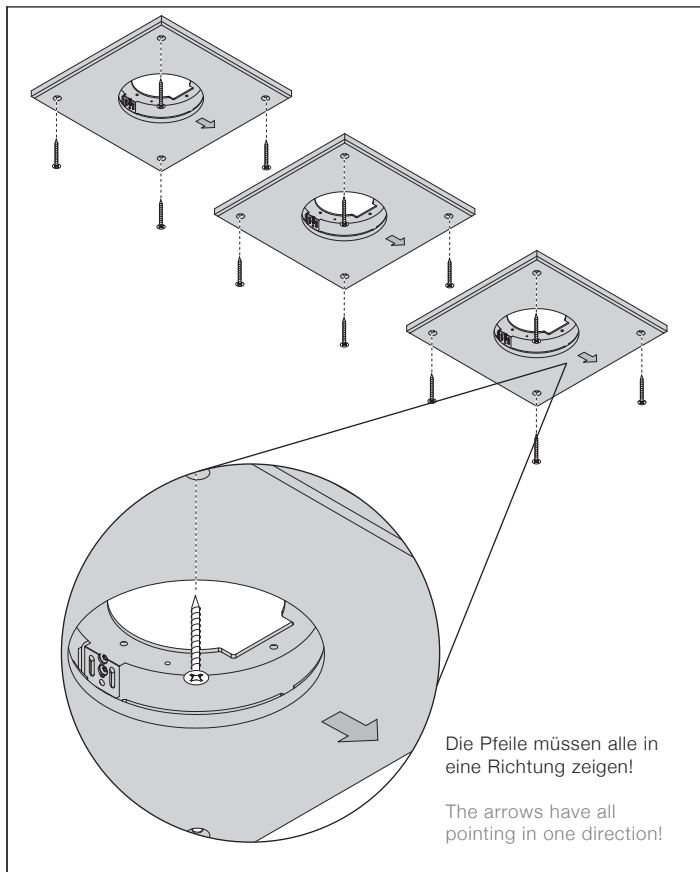

Sento sospeso trimless fixed length

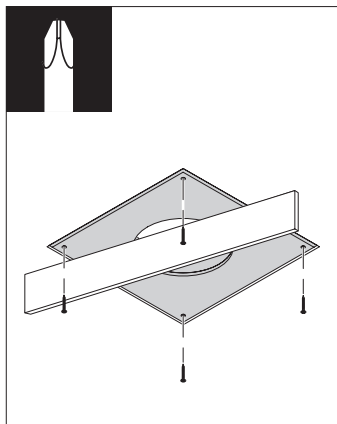

Fit the drywalling plate in the opening correctly so that it is flush. To do so, use the drilled holes provided. If the plate is to be fixed in any other position, pre-drill holes before screwing it in place in order to avoid damaging the drywalling plate.



Caution!

The manufacturer expressly indicates that if the drywalling plate has not been properly fitted, it may fall, thereby posing a significant danger.

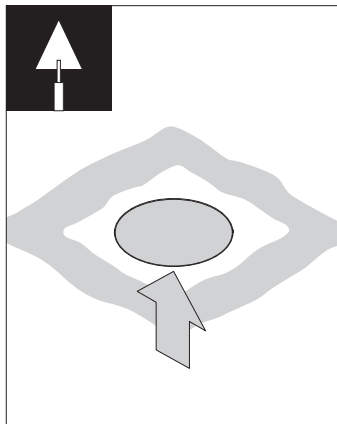

Place the protective cover in the opening.

Plaster over the joins.

Ensure that the inside of the mounting ring is kept clean.

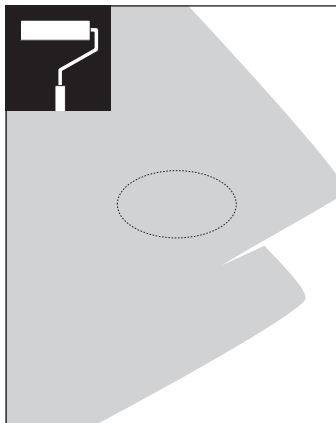

Carry out any painting and decorating work.

Ensure that the inside of the mounting ring is kept clean.

Remove the protective cover.

If necessary, remove any residual plaster/paint from the inside of the mounting ring using fine sandpaper.



Caution!

Before fitting, disconnect all current-carrying lines from the mains supply.

Sento sospeso trimless fixed length

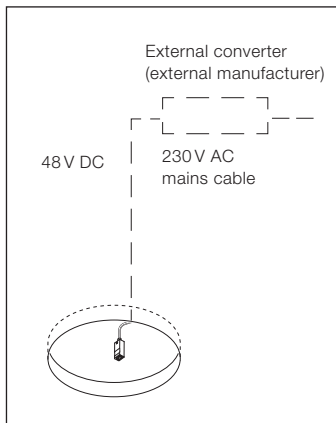

Connecting a converter from an external manufacturer (see supplementary sheet for the converter):

Connect the converter to the mains cable as shown in the wiring diagram. Connect the cable with the LED socket to the converter. Observe the technical instructions of the particular manufacturer.

Black = positive pole, white = negative pole Guide the socket of the LED extension cable to the outside through the hollow ceiling/plastering box.

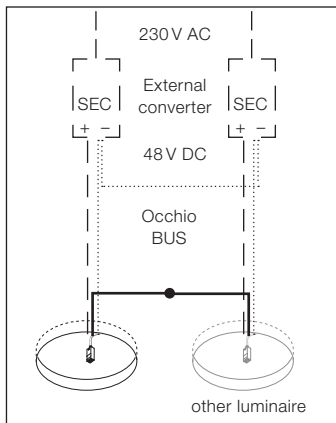

Occhio BUS (optional)

By connecting the Occhio BUS cable, it is possible to control several luminaires synchronously using »touchless control«. To do so, set the head to the „DIM“ setting.

The cables marked with BUS are connected to one another using a suitable terminal. With several converters, the negative poles (SEC) must be connected to each other. Other cables are connected as specified above.

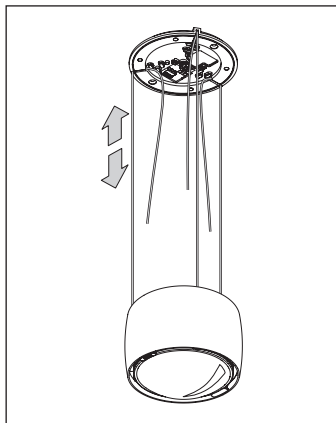

Roughly adjust the length of suspension by pulling the cables.

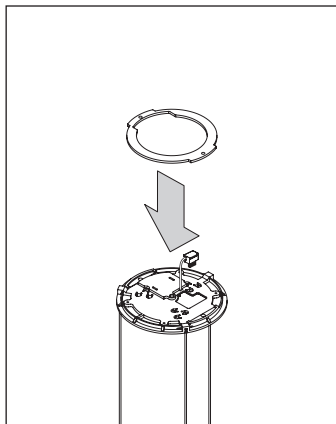

Place the spacing ring onto the luminaire's cable holder so that it is flush.

Sento sospeso trimless fixed length

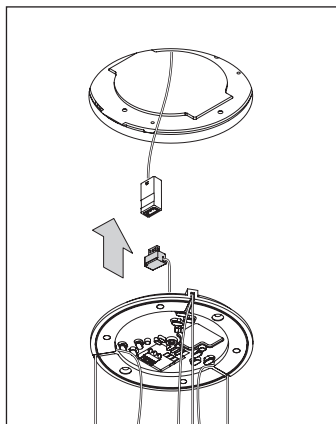

Connect the luminaire to the socket of the LED connection cable.

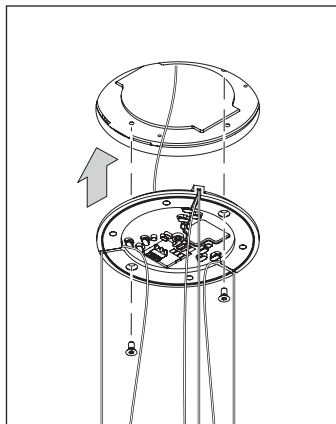

Push the plug connection back into the hollow space.

Screw the cable holder to the holder in the drywalling plate using the screws (Allen) provided.

When installing more than one luminaire, ensure that the cable holders have the same orientation.

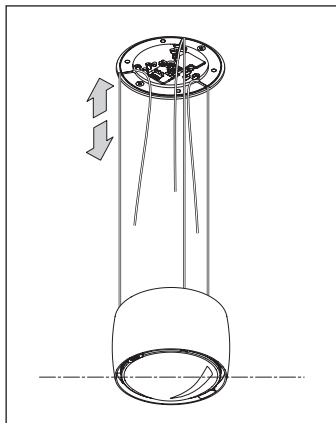

Set the final length of the cables by pulling them. In doing so, ensure that all three cables are exactly the same length and that the head hangs level.

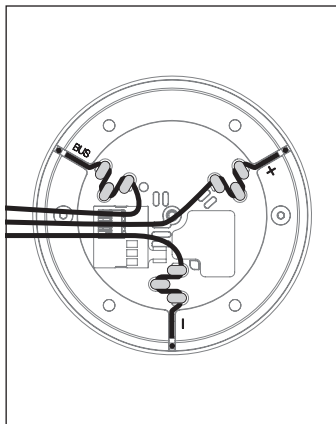

Thread each of the three loose cables into the respective cable grip, in accordance with the diagram.

Sento sospeso trimless fixed length

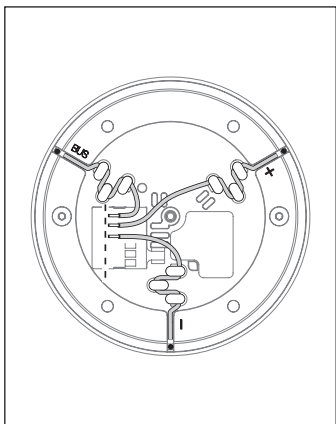

Shorten the cables as necessary and strip 6–7 mm of insulation from the ends.

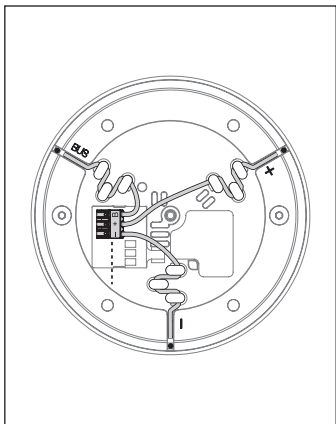

Connect all cables to the terminals.

Correct polarity must be observed.

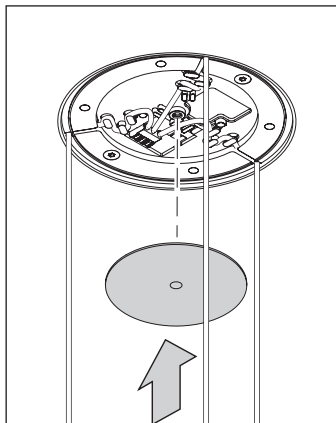

Screw the cable cover onto the cable holder.

Ensure that all cables lie flush.

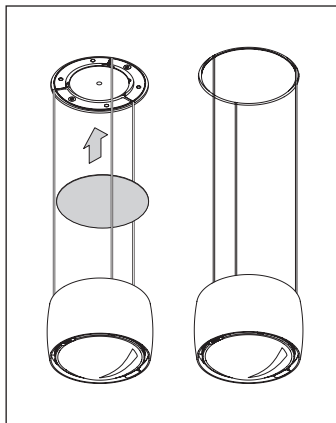

Put the cover in place. It is held in place by magnets.

The luminaire is now fully assembled.

Sento sospeso trimless fixed length

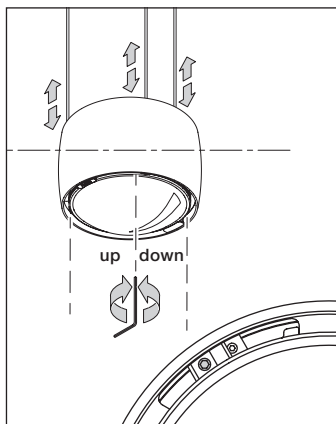

Adjusting the head vertically

If the head does not hang completely level, it can be readjusted by ± 5 mm at each of the three suspension cables using the Allen key provided.



Appendix

Care instructions

Always allow the luminaire to cool down before cleaning.

To clean the luminaire, use a dry microfibre cloth or the Occhio cleaning agent.

Information & contact

Your Occhio specialist retailer will gladly answer any other questions

www.occhio.de

info@occhio.de

Technical data

Technical data luminaire

Product designation	Occhio Sento sospeso
head	ø 123 mm, H 72 mm
up version with height adjustment	base ø 108 mm, H 62 mm, adjustable range: 500–2000 mm
flat version with height adjustment	base ø 108 mm, H 38 mm, adjustable range: 500–2000 mm
trimless version with height adjustment	Plastering element 250x250mm, H 12.5mm Adjustable range: 500–2000 mm
up version fixed length	base ø 108 mm, H 38 mm, length max. 3500 mm
flat version fixed length	base ø 108 mm, H 15 mm, length max. 3500 mm
trimless version fixed length	Plastering element 250x250mm, H 12.5mm Length: max. 3500mm
Safety class	up versions: 2; flat/trimless versions: 3
Connection	up versions: 230V AC, 50 Hz flat/trimless versions: 48V DC, min. 40W
Power supply unit	up versions: integrated flat/trimless versions: external
Dimming	Via »touchless sensor« integrated in the head or: up versions: by trailing-edge phase-cut dimmer or Occhio air (for a list of compatible dimmers, see www.occhio.de/dim_en , trailing-edge phasecut dimmer can not be combined with »touchless control« and Occhio air) flat version: With suitable power supply unit

Technical data luminaire

Material	Aluminium, chrome-plated, painted or anodised steel, plastic, fibre-cement plate, Glass, optical plastic
LED power	32 W (26 W head shiny chrome)
Permitted operating conditions	Max. 30 °C (for indoor use only)
Test symbols	IP 20 CE    up:  flat/trimless: 

Technical data light source

Light source	Occhio LED
Version	LED chip (replaceable)
Life time	> 50.000 h
Energy efficiency class – EEC	A+ / A

Disposal

Dispose of at the local waste disposal site. Sento sospeso is recyclable and RoHS-compliant. **Do not dispose of with household waste.**

Occhio

Occhio GmbH
Wiener Platz 7
81667 München
Fon +49-89-44 77 86 30
Fax +49-89-44 77 86 39
info@occhio.de
www.occhio.de



010404295680856510